

## Motor Protection Circuit Breaker

We touch your **electricity** everyday!

### State of the art Manufacturing Facilities



Haridwar, Noida Ph-I  
& Noida Ph-II Plant



#### C&S Electric Ltd.

Corporate Office : 222, Okhla Industrial Estate, New Delhi - 110 020  
Tel. : +91-11-3088 7520 - 29, Fax: +91-11-2684 7154, 2682 9063

International Business Division: Tel. : +91-11-4161 3503, 3088 7520-29, Fax: +91-11-2683 8291, 2684 7342  
email : exports@cselectric.co.in

Central Marketing Office: Tel. : +91-11-3088 7520-29, Fax: +91-11-2684 8241, 2684 7342  
email : cmo@cselectric.co.in, info@cselectric.co.in



MPCB

# Motor Protection Circuit Breaker up to 100A



up to 32A

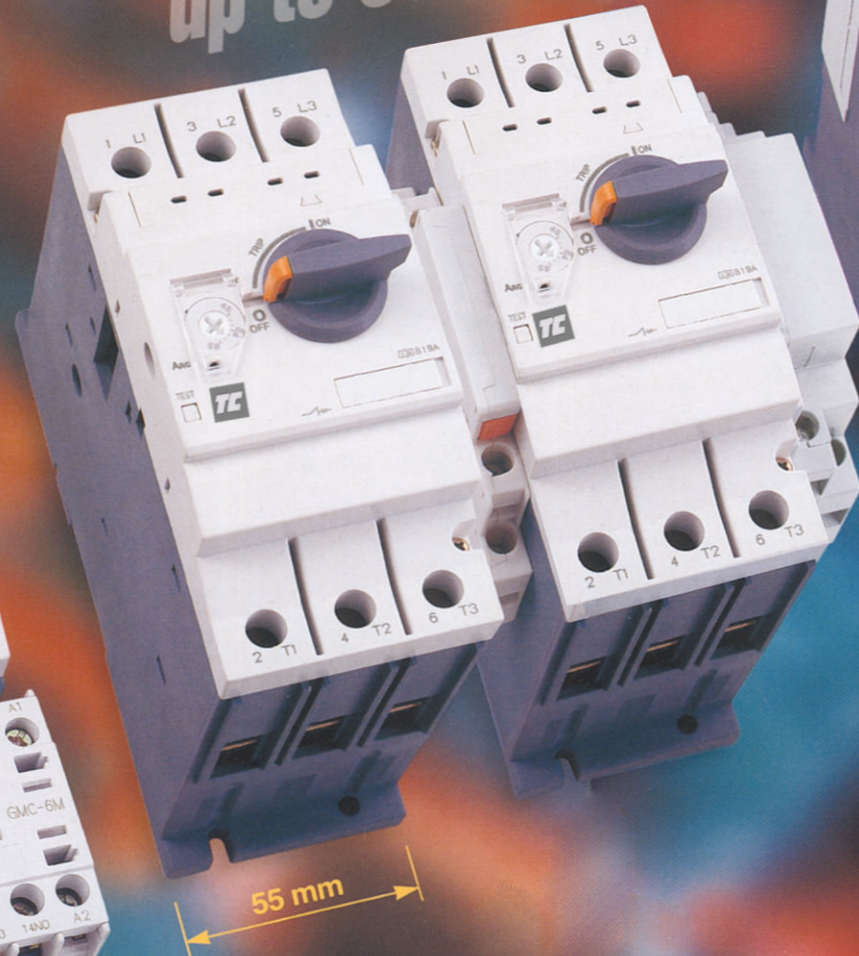

up to 63A

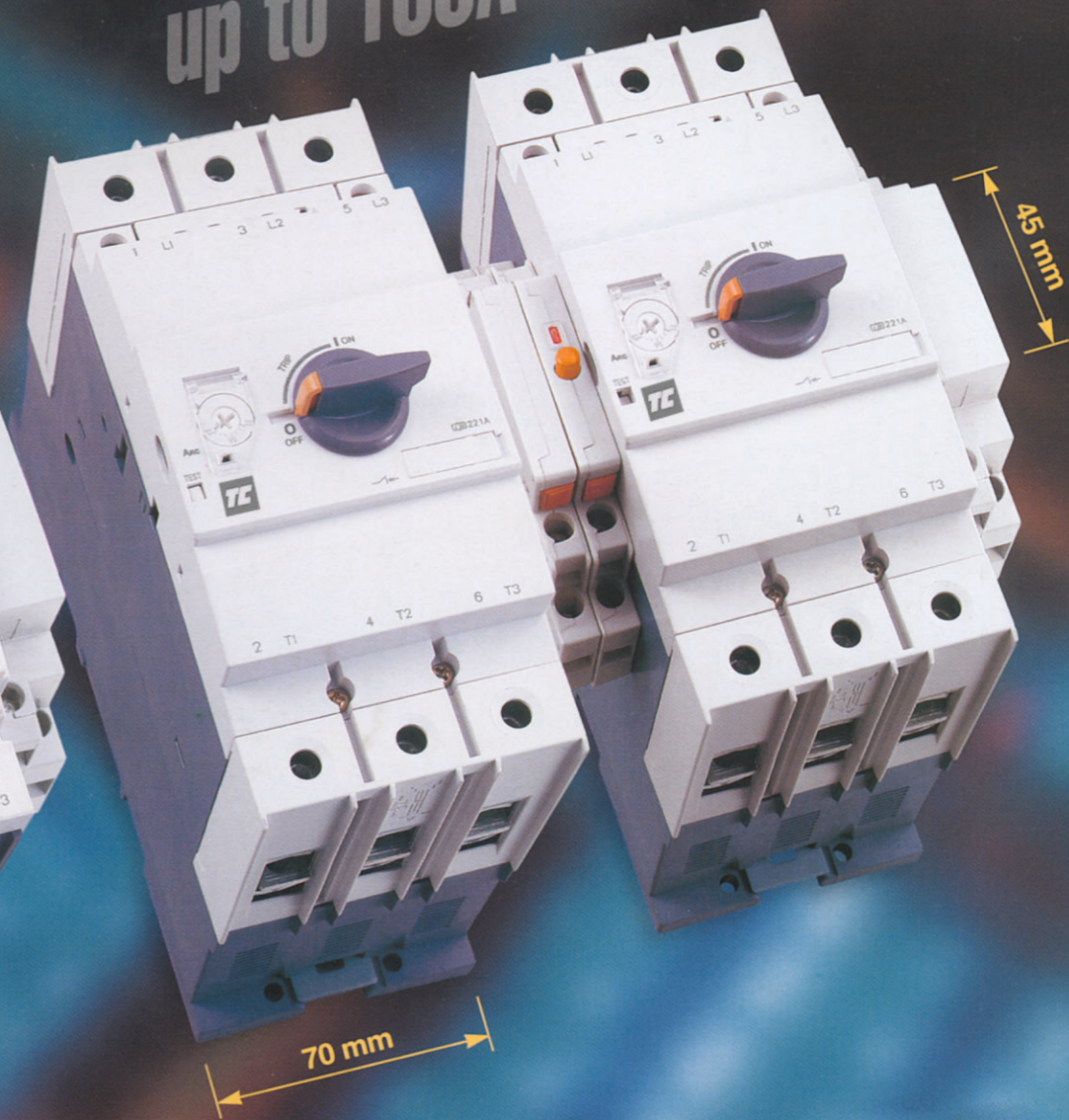

up to 100A

## 32AF

0.1~0.16...22~32A (16 step)

TCMS-32S



• Standard

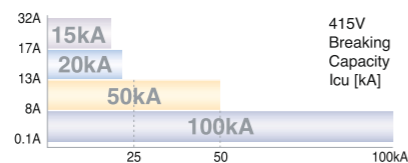

TCMS-32H  
TCMS-32HI



• High break  
• Magnetic release

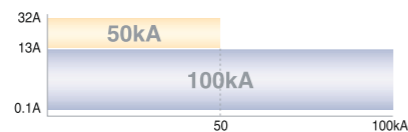

28~63A (3 step)

TCMS-63S



• Standard

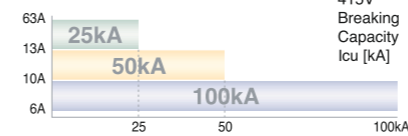

TCMS-63H  
TCMS-63HI



• High break  
• Magnetic release

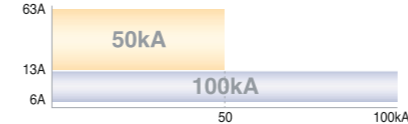

## 63AF

55~100A (3 step)

TCMS-100S



• Standard

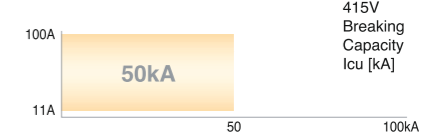

TCMS-100H  
TCMS-100HI



• High break  
• Magnetic release

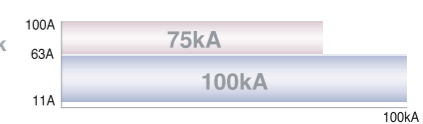

## 100AF

Motor Protection Circuit Breaker, versatile efficient technologically advance compact design



Handle Lock

Dial Cover

Terminals



Common wide variety of accessories from 32~100A frame size enable a flexible response to changes in specifications, saves inventory cost.

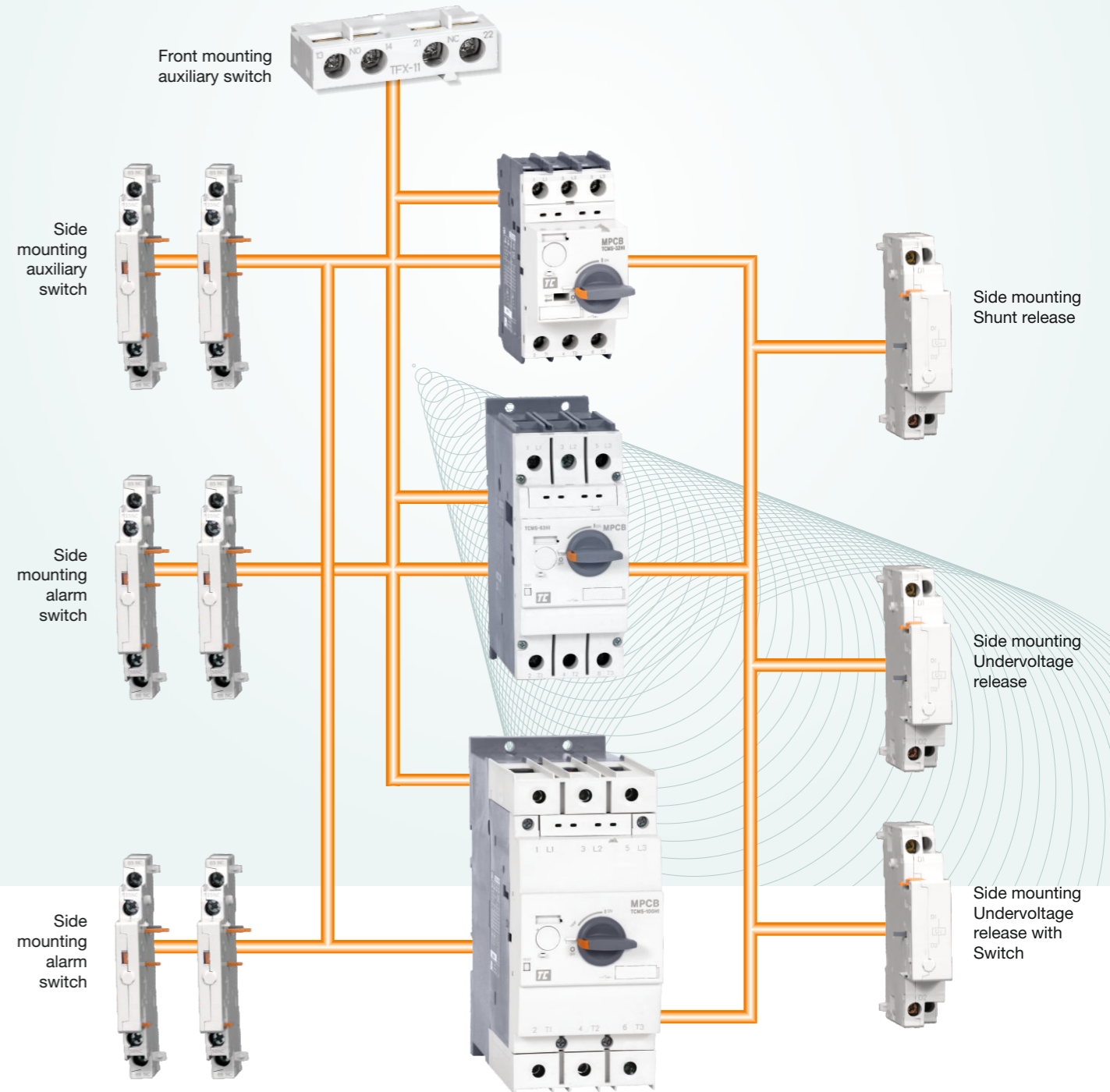

## Benefits

- Motor Protection
- Isolation
- Phase failure protection
- Current limiting Short Circuit Protection
- Class 10 trip class protection
- Tested for Icu / Ics at 690V
- Ambient temperature compensation
- Common accessories for complete range

## Advantages

- Rated Insulation voltage 690V
- Complete range in #3 frames sizes 45mm upto 32A, 55mm upto 63A & 70mm upto 100A
- Adjustable Thermal release
- Trip test
- Three position operator: ON-OFF trip
- Handle locks in the OFF position
- Finger safe terminal
- 35 Din rail mounting

## Standards

### Compliance with International Standards

- IEC 60947-2 & IEC 60947-4-1
- UL508 (Manual Motor Controller in group installation)
- CSA C22-2 no 14

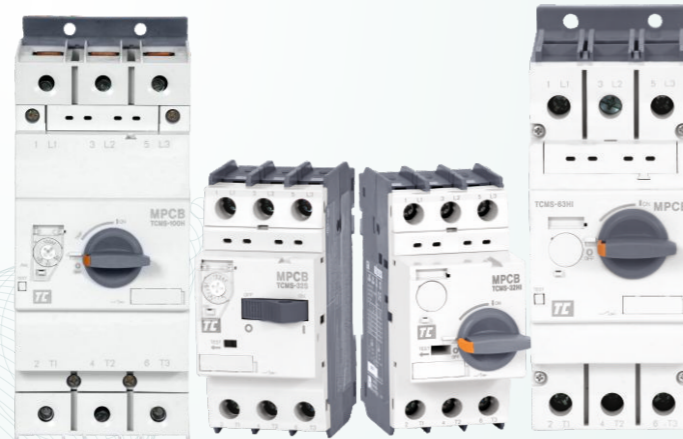

## Global Accreditations



## Product Selection Guide

■ Quick Selection table...IEC rating	7
■ Motor Protection	9
■ Short Circuit Protection for Motor Controller	11
■ Accessories: Electrical Auxiliaries	12

## Technical Information

■ General Data	17
■ IEC Performance Data (Motor Protection)	22
■ Type '2' Coordination as per IEC 947-4-1	25
■ Time / Current Characteristics	27
■ Dimensions	28

## Quick selection table... IEC rating



TCMS-32S



TCMS-32HI

Frame			32AF																			
Type	Current adjustable type		TCMS-32S						TCMS-32H													
	Instantaneous type		-						-													
Breaking capacity			Standard						High breaking													
Handle Type			Toggle						Rotary													
Number of poles			3						3													
Rated operational voltage (Ue)			Up to 690V						Up to 690V													
Rated frequency			50/60 Hz						50/60 Hz													
Rated insulation voltage (Ui)			690V						690V													
Rated impulse voltage (Uimp)			6kV						6kV													
Utilization category	IEC 60 947-2 (Breaker)		Cat. A						Cat. A													
	IEC 60 947-4 (Motor starter)		AC 3						AC 3													
Mechanical endurance (Operating)			100,000						100,000													
Electrical endurance (Cycles)			100,000						100,000													
Max operating frequency per hour (Oprn./h)			25						25													
Temperature compensation (Operation)			-20 ~ +60 °C						-20 ~ +60 °C													
Instantaneous short circuit release			13 x Ie max.						13 x Ie max.													
Overload protection			O						O													
Phase failure function			O						O													
Trip indicating function			O						O													
Test function			O						O													
Weight (g)			320						360													
Rated breaking capacity (kA)	Rated operational current (Ie)	Thermal release Adjustment range (A)	240V* 230V#		415V* 400V#		460V* 440V#		525V* 500V#		690V* 600V#		230V* 240V#		415V* 400V#		460V* 440V#		525V* 500V#		690V* 600V#	
			Icu	Ics	Icu	Ics	Icu	Ics	Icu	Ics	Icu	Ics	Icu	Ics	Icu	Ics	Icu	Ics	Icu	Ics	Icu	Ics
0.16	0.16	0.1-0.16	100	100	100	100	100	100	100	100	100	100	100	100	100	100	100	100	100	100	100	100
0.25	0.25	0.16-0.25	100	100	100	100	100	100	100	100	100	100	100	100	100	100	100	100	100	100	100	100
0.4	0.4	0.25-0.4	100	100	100	100	100	100	100	100	100	100	100	100	100	100	100	100	100	100	100	100
0.63	0.63	0.4-0.63	100	100	100	100	100	100	100	100	100	100	100	100	100	100	100	100	100	100	100	100
1	1	0.63-1	100	100	100	100	100	100	100	100	100	100	100	100	100	100	100	100	100	100	100	100
1.6	1.6	1-1.6	100	100	100	100	100	100	100	100	3	3	100	100	100	100	100	100	100	100	100	100
2.5	2.5	1.6-2.5	100	100	100	100	100	100	50	38	3	3	100	100	100	100	100	100	100	8	8	8
4	4	2.5-4	100	100	100	100	50	38	15	11	3	3	100	100	100	100	100	100	100	8	8	8
6	6	4-6	100	100	100	100	15	11	10	8	3	3	100	100	100	100	100	100	100	6	6	6
8	8	5-8	100	100	100	100	15	11	10	8	3	3	100	100	100	100	50	38	50	38	6	6
10	10	6-10	100	100	50	38	15	11	6	5	3	3	100	100	100	100	50	38	50	38	6	6
13	13	9-13	100	100	50	38	10	8	6	5	3	3	100	100	100	100	50	38	42	32	6	6
17	17	11-17	50	38	20	15	10	8	6	5	3	3	100	100	50	38	20	15	10	8	4	4
22	22	14-22	40	30	15	11	8	6	6	5	3	3	100	100	50	38	20	15	10	8	4	4
26	26	18-26	40	30	15	11	8	6	6	5	3	3	100	100	50	38	20	15	10	8	4	4
32	32	22-32	30	22	15	11	6	4	5	4	3	3	100	100	50	38	20	15	10	8	4	4
40	40	28-40	-	-	-	-	-	-	-	-	-	-	-	-	-	-	-	-	-	-	-	-
50	50	34-50	-	-	-	-	-	-	-	-	-	-	-	-	-	-	-	-	-	-	-	-
63	63	45-63	-	-	-	-	-	-	-	-	-	-	-	-	-	-	-	-	-	-	-	-
75	75	55-75	-	-	-	-	-	-	-	-	-	-	-	-	-	-	-	-	-	-	-	-
90	90	70-90	-	-	-	-	-	-	-	-	-	-	-	-	-	-	-	-	-	-	-	-
100	100	80-100	-	-	-	-	-	-	-	-	-	-	-	-	-	-	-	-	-	-	-	-

\* Permissible up to 5% over Voltage  
# Permissible up to 5% over Voltage



TCMS-63H



TCMS-100H

63AF										100AF									
TCMS-63H					TCMS-32HI					High break					High breaking				
High break					Rotary					Rotary					Rotary				
3					3					3					3				
Up to 690V					Up to 690V					Up to 690V					Up to 690V				
50 / 60 Hz					50 / 60 Hz					50 / 60 Hz					50 / 60 Hz				
1000V					1000V					1000V					1000V				
8kA					8kA					8kA					8kA				
Cat. A					Cat. A					Cat. A					Cat. A				
AC 3					AC 3					AC 3					AC 3				
50,000					50,000					50,000					50,000				
25,000					25,000					25,000					25,000				
25					25					25					25				
- 20 ~ 60 °C					- 20 ~ 60 °C					- 20 ~ 60 °C					- 20 ~ 60 °C				
13 x Ie max.O					13 x Ie max.O					13 x Ie max.O					13 x Ie max.O				
O					O					O					O				
O					O					O					O				
O					O					O					O				
1,000					1,000					2,200					2,200				
240V 230V		415V 400V		460V 440V		525V 500V		690V 600V		240V 230V		415V 400V		460V 440V		525V 500V		690V 600V	
Icu	Ics	Icu	Ics	Icu	Ics	Icu	Ics	Icu	Ics	Icu	Ics	Icu	Ics	Icu	Ics	Icu	Ics	Icu	Ics
-	-	-	-	-	-	-	-	-	-	-	-	-	-	-	-	-	-	-	-
-	-	-	-	-	-	-	-	-	-	-	-	-	-	-	-	-	-	-	-
-	-	-	-	-	-	-	-	-	-	-	-	-	-	-	-	-	-	-	-
-	-	-	-	-	-	-	-	-	-	-	-	-	-	-	-	-	-	-	-
-	-	-	-	-	-	-	-	-	-	-	-	-	-	-	-	-	-	-	-
-	-	-	-	-	-	-	-	-	-	-	-	-	-	-	-	-	-	-	-
-	-	-	-	-	-	-	-	-	-	-	-	-	-	-	-	-	-	-	-
-	-	-	-	-	-	-	-	-	-	-	-	-	-	-	-	-	-	-	-
100	100	100	100	50	38	50	38	6	5	-	-	-	-	-	-	-	-	-	-
100	100	100	100	50	38	42	32	6	5	-	-	-	-	-	-	-	-	-	-
100	100	50	50	50	38	12	9	5	5	100	100	100	50	50	38	35	27	12	9
100	100	50	50	50	38	12	9	5	5	100	100	100	50	50	38	35	27	12	9
100	100	50	50	35	27	10	8	5	5	100	100	100	50	50	38	25	19	12	9
100	100	50	50	35	27	10	8	5	5	100	100	100	50	50	38	25	15	12	9
100	100	50	50	35	27	10	8	5	5	100	100	100	50	50	38	15	11	10	8
100	100	50	50	35	27	10	8	5	5	100	100	100	50	50	38	15	11	8	6
-	-	-	-	-	-	-	-	-	-	100	100	100	50	50	38	12	9	6	6
-	-	-	-	-	-	-	-	-	-	100	100	100	50	50	38	12	9	6	6
-	-	-	-	-	-	-	-	-	-	100	100	100	50	50	38	12	9	6	6

## Motor Protection

- Adjustable thermal release
- Magnetic release 13 le max.
- Trip class 10
- Protective function
  - Phase-failure protection
  - short circuit
  - overload
- Ambient temperature compensation



Type	Rated operational current $I_n$ [A]	Thermal release Adjustment range [A]	Magnetic release Operating current [A]	Switching of 3 phase AC motor, AC-2, AC-3						400 / 415V	
				3-phase [kW] (50 / 60Hz)			3-phase [HP] (60Hz)			$I_{cu}$ [kA]	$I_{cs}$ [kA]
				230V	400V	690V	230V	460V	575V		
TCMS-32S (Standard)	0.16	0.1...0.16	2.1	-	0.02	-	-	-	-	100	100
	0.25	0.16...0.25	3.3	0.03	0.06	-	-	-	-	100	100
	0.4	0.25...0.4	5.2	0.06	0.09	-	-	-	-	100	100
	0.63	0.4...0.63	8.2	0.09	0.12	0.25	-	-	-	100	100
	1	0.63...1.0	13	0.12	0.25	0.55	-	1/2	1/2	100	100
	1.6	1.0...1.6	20.8	0.25	0.55	1.1	1/3	3/4	1	100	100
	2.5	1.6...2.5	32.5	0.37	0.75	1.5	1/2	1.5	1.5	100	100
	4	2.5...4.0	52	0.75	1.5	3	1	2	3	100	100
	6	4...6	78	1.5	2.2	4	1.5	5	5	100	100
	8	5...8	104	1.5	3	5.5	2	5	5	100	100
	10	6...10	130	3	4	7.5	3	7.5	10	50	38
	13	9...13	169	3	5.5	11	3	7.5	10	50	38
	17	11...17	221	4	7.5	11	5	10	15	20	15
	22	14...22	286	4	7.5	15	7.5	15	20	15	11
26	18...26	338	5.5	11	18.5	7.5	15	20	15	11	
32	22...32	416	7.5	15	22	10	20	30	15	11	
TCMS-32H (High Break)	0.16	0.1...0.16	2.1	-	0.02	-	-	-	-	100	100
	0.25	0.16...0.25	3.3	0.03	0.06	-	-	-	-	100	100
	0.4	0.25...0.4	5.2	0.06	0.09	-	-	-	-	100	100
	0.63	0.4...0.63	8.2	0.09	0.12	0.25	-	-	-	100	100
	1	0.63...1.0	13	0.12	0.25	0.55	-	1/2	1/2	100	100
	1.6	1.0...1.6	20.8	0.25	0.55	1.1	1/3	3/4	1	100	100
	2.5	1.6...2.5	32.5	0.37	0.75	1.5	1/2	1.5	1.5	100	100
	4	2.5...4.0	52	0.75	1.5	3	1	2	3	100	100
	6	4...6	78	1.5	2.2	4	1.5	5	5	100	100
	8	5...8	104	1.5	3	5.5	2	5	5	100	100
	10	6...10	130	3	4	7.5	3	7.5	10	100	100
	13	9...13	169	3	5.5	11	3	7.5	10	100	100
	17	11...17	221	4	7.5	11	5	10	15	50	38
	22	14...22	286	4	7.5	15	7.5	15	20	50	38
26	18...26	338	5.5	11	18.5	7.5	15	20	50	38	
32	22...32	416	7.5	15	22	10	20	30	50	38	

- Adjustable thermal release
- Magnetic release 13 le max.
- Trip class 10
- Protective function
  - Phase-failure protection
  - short circuit
  - overload
- Ambient temperature compensation

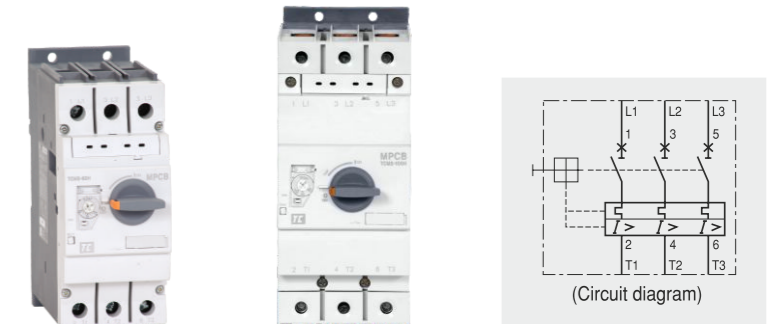

Type	Rated operational current $I_n$ [A]	Thermal release Adjustment range [A]	Magnetic release Operating current [A]	Switching of 3 phase AC motor, AC-2, AC-3						400 / 415V	
				3-phase [kW] (50 / 60Hz)			3-phase [HP] (60Hz)			$I_{cu}$ [kA]	$I_{cs}$ [kA]
				230V	400V	690V	230V	460V	575V		
TCMS-63H (High Break)	10	6~10	130	3	4	7.5	3	7.5	10	100	100
	13	9~13	169	3	5.5	11	3	7.5	10	100	100
	17	11~17	221	4	7.5	11	5	10	15	50	50
	22	14~22	286	4	7.5	15	7.5	15	20	50	50
	26	18~26	338	5.5	11	18.5	10	20	25	50	50
	32	22~32	416	7.5	15	22	10	25	30	50	50
	40	28~40	520	7.5	18.5	30	15	30	40	50	50
	50	34~50	650	11	22	45	15	40	50	50	50
	63	45~63	819	15	30	55	20	50	60	50	50
	TCMS-100H (High Break)	17	11~17	221	4	7.5	11	5	10	15	100
22		14~22	286	4	7.5	15	7.5	15	20	100	50
26		18~26	338	5.5	11	18.5	10	20	25	100	50
32		22~32	416	7.5	15	22	10	25	30	100	50
40		28~40	520	7.5	18.5	30	15	30	40	100	50
50		34~50	650	11	22	45	15	40	50	100	50
63		45~63	819	15	30	55	20	50	60	100	50
75		55~75	975	22	37	63	25	60	75	75	50
90		70~90	1170	30	45	75	30	75	100	75	50
100		80~100	1300	30	45	90	40	75	100	75	50







## Short Circuit Protection for Motor Controller

- Without thermal releases
- Magnetic release 13 x I<sub>e</sub> max
- Protective function
  - Short Circuit

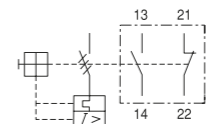
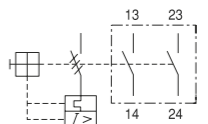
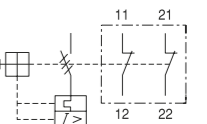

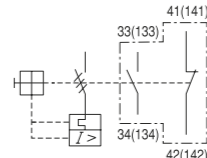
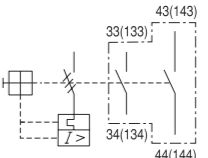
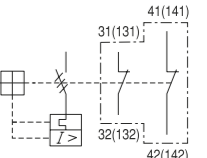
Type	Rated operational current I <sub>e</sub> [A]	Thermal release Adjustment range [A]	Magnetic release Operating current [A]	Switching of 3 phase AC motor, AC-2, AC-3						400 / 415V	
				3-phase [kW] (50 / 60Hz)			3-phase [HP] (60Hz)			I <sub>cu</sub> [kA]	I <sub>cs</sub> [kA]
				230V	400V	690V	230V	460V	575V		
TCMS-32HI (Standard)	0.16	-	2.1	-	0.02	-	-	-	-	100	100
	0.25	-	3.3	0.03	0.06	-	-	-	-	100	100
	0.4	-	5.2	0.06	0.09	-	-	-	-	100	100
	0.63	-	8.2	0.09	0.12	0.25	-	-	-	100	100
	1	-	13	0.12	0.25	0.55	-	1/2	1/2	100	100
	1.6	-	20.8	0.25	0.55	1.1	1/3	3/4	1	100	100
	2.5	-	32.5	0.37	0.75	1.5	1/2	1.5	1.5	100	100
	4	-	52	0.75	1.5	3	1	2	3	100	100
	6	-	78	1.5	2.2	4	1.5	5	5	100	100
	8	-	104	1.5	3	5.5	2	5	5	100	100
	10	-	130	3	4	7.5	3	7.5	10	100	100
	13	-	169	3	5.5	11	3	7.5	10	100	100
	17	-	221	4	7.5	11	5	10	15	50	38
22	-	286	4	7.5	15	7.5	15	20	50	38	
26	-	338	5.5	11	18.5	7.5	15	20	50	38	
32	-	416	7.5	15	22	10	20	30	50	38	
TCMS-63HI (High Break)	10	-	130	3	4	7.5	3	7.5	10	100	100
	13	-	169	3	5.5	11	3	7.5	10	100	100
	17	-	221	4	7.5	11	5	10	15	50	50
	22	-	286	4	7.5	15	7.5	15	20	50	50
	26	-	338	5.5	11	18.5	10	20	25	50	50
	32	-	416	7.5	15	22	10	25	30	50	50
TCMS-100HI (High Break)	40	-	520	7.5	18.5	30	15	30	40	50	50
	50	-	650	11	22	45	15	40	50	50	50
	63	-	819	15	30	55	20	50	60	100	50
	75	-	975	22	37	63	25	60	75	75	50
	90	-	1170	30	45	75	30	75	100	75	50
	100	-	1300	30	45	90	40	75	100	75	50

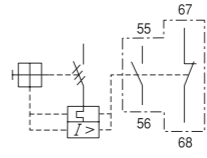
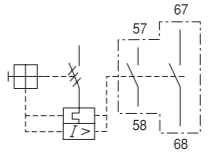
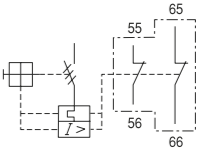
## Accessories (Electrical Auxiliaries)

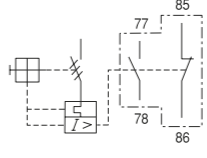
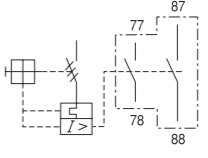
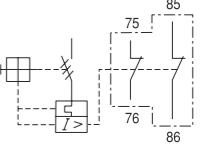
Model	Description	Connection diagram		
<b>TFX...</b>	<b>Auxiliary Switch</b> <ul style="list-style-type: none"> <li>Front mounting</li> <li>2-pole</li> <li>One front mounting module per circuit breaker</li> </ul>	1NO1NC	2NO	2NC
				
<b>TLX...</b>	<b>Auxiliary Switch</b> <ul style="list-style-type: none"> <li>Side mounting on the left</li> <li>2-pole</li> <li>One side mounting module per circuit breaker</li> </ul>	1NO1NC	2NO	2NC
				
<b>TLA...</b>	<b>Any Trip Alarm Switch</b> <ul style="list-style-type: none"> <li>Operates in case of trip</li> <li>Side mounting on the left</li> <li>2-pole</li> <li>Set TLA first in case of using TLX together</li> <li>(TCMS-63 can not accept TLX and TLA together)</li> </ul>			
				
<b>TAM...</b>	<b>Magnetic Trip Alarm Switch</b> <ul style="list-style-type: none"> <li>Operates in case of instantaneous trip</li> <li>Side mounting on the left</li> <li>2-pole</li> <li>Set TLAM first in case of using TLX together</li> </ul>			
				

Accessories (Electrical Auxiliaries)

Model	Description	Connection diagram	
TRS...	<b>Shunt release</b> <ul style="list-style-type: none"> <li>Side mounting on the right</li> <li>One side mounting module per circuit breaker.</li> <li>Can not use with TRU or TRUX</li> </ul>		110~127 Hz 220~230V 50Hz 415~440V 50Hz
TRU...	<b>Undervoltage release</b> <ul style="list-style-type: none"> <li>Side mounting on the right</li> <li>One side mounting module per circuit breaker.</li> <li>Can not use with TRU or TRUX</li> </ul>		110~127V 50Hz 220~230V 50Hz 415~440V 50Hz
TRX...	<b>Undervoltage release with Switch</b> <ul style="list-style-type: none"> <li>Side mounting on the right</li> <li>Include 2NO Auxiliary contact</li> <li>One side mounting module per circuit breaker.</li> <li>Can not use with TRU or TRUX</li> <li>Can not attach to TCMS-32S</li> </ul>		110~127V 50Hz 220~230V 50Hz 415~440V 50Hz

E-Handle (Rotary-type)



TCMS E-Handle is a Rotary-type Handle accessory which can be attached to the front to control and verify the ON, TRIP, OFF condition of Manual Motor Starters under the situation of closing panel.

- Application Model: TCMS-32H/Hi, TCMS-63S/H/Hi, TCMS-100S/H/Hi
- Operation temp.: -20~ +60°C
- Degree of protection: Ip65
- Material of insulation: Plastic (PA66)
- CE and UL certified
- Locking device: Lockable in on/off position

Type	Application MMS	Remarks
MEH-32	TCMS-32H, 32HI	Length of shaft: 115 or 315mm
MEH-63	TCMS-63S, 63H, 63HI	
MEH-100	TCMS-100S, 100H, 100HI	

Phase Bus



It is a device for a parallel connection with power terminals in the circuit lined up by TCMS, and it can provides the solution "Simple wiring" and "Compact wiring space".

- Application Model : TCMS-32, 63
- Safety Cover built-in
- CE and UL certified
- RoHS compliance

Type	Application MMS	Number of Terminals	Rated current	Safety cover attached
PB-322	TCMS-32S, 32H, 32HI	2	63A	PBPC-32 (32for S, H)
PB-323		3		
PB-632	TCMS-63S, 63H, 63HI	2	108A	PBPC-63
PB-633		3		

Phase Bus

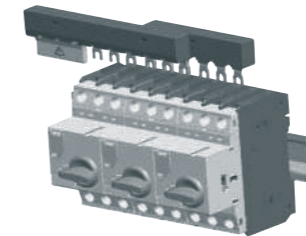

Diagram

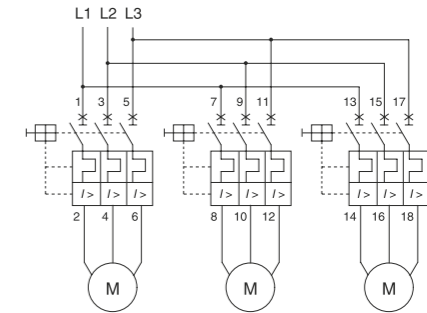

Enclosure

Case cover of TCMS enclosure is specifically designed with dust-proof and corrosive-proof structure. Therefore, it is the optimum product to use in dusty areas such as cement plants, cotton mills as well as in the presence of corrosive gas or liquid (excl. explosive, flammable gas) such as fertilizer, refinery, and plating plant.

- Application Model: TCMS - 32H / HI
- CE and UL certified
- Material of insulation: Plastic (ABS)
- Operation temperature : -20~ +60°C
- Degree of protection: Ip65

Type	Application TCMS	Remarks
EPH-32	TCMS-32H, 32HI	Surface mount

Dial Cover

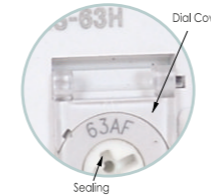

Dial cover is used to protect the set value from the operation that is not intended.

It is supplied as standard for all TCMS

- Application Model: TCMS-32, 63, 100 (All types)

Insulation Barrier

Insulation barrier is used to enlarge the creepage distance and clearance to meet the requirement of UL.

- Application Model: TCMS-100

Type	Application TCMS
TIB100	TCMS-100S, 100H, 100HI

Screw mounting holder

32AF TCMS is only for DIN rail mountable by itself. Screw mounting holder is used to mount TCS on a panel by screws.

- Application Model : TCMS-32

Type	Application TCMS	Remarks
TMP 32	TCMS-32S, 32H, 32HI	For M4 screw

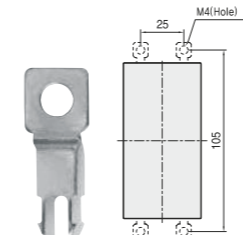



## Accessories (Electrical Auxiliaries)

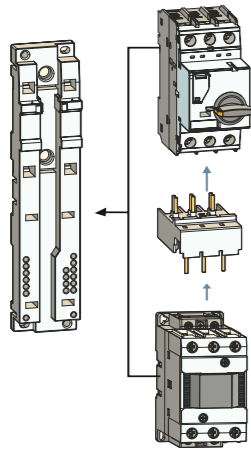

### Direct adaptor and Mounting unit

#### Direct adaptor, DA

Direct adaptor is used to connect TCMS directly with a contactor

#### Mounting unit, MU

This device is attached module to connect joined TCMS with a contactor

- Application Model: TCMS+contactor TCIM06~16 / TPIM06~16 Mini contactor

Type		Combine Devices	
Direct adaptor	Mounting Unit	TCMS	MC
TDA-32SA	MU-45	TCMS-32S	Mini MC TCIM06~16
TDA-32HA		TCMS-32H, 32HI	
TDA-32SD		TCMS-32S	Mini MC TDIM06~16
TDA-32HD		TCMS-32H, 32HI	

## Terminals

	TCMS32S	TCMS32H	TCMS63S, 63H	TCMS100S, 100H
Conformity to standards	IEC60947 UL508, UL508 Type E			
Approvals	CE, UL			
Terminal parts				
Screwdriver				
Single-core	1.conductor [mm] / [AWG] 1...10 / 18...8	1...10 / 18...8	0.75...35 / 18...2	2.5...70 / 12...2/0
2.conductor	[mm] / [AWG] 1...6 / 18...10	1...6 / 18...10	0.75...25 / 18...4	2.5...50 / 12...1/0
Standard	1.conductor [mm] / [AWG] 1...6 / 18...10	1...6 / 18...10	0.75...35 / 18...2	2.5...70 / 12...2/0
2.conductor	[mm] / [AWG] 1...6 / 18...10	1...6 / 18...10	0.75...25 / 18...4	2.5...50 / 12...1/0
Flexible	1.conductor [mm] / [AWG] 1...6 / 18...10	1...6 / 18...10	0.75...25 / 18...4	2.5...50 / 12...1/0
2.conductor	[mm] / [AWG] 0.75...4 / 18...10	0.75...4 / 18...10	0.75...16 / 18...6	2.5...35 / 10...2
Tightening torque	[Nm] / [lb-in] 0.8...2.5 / 7...22	0.8...2.5 / 7...22	3...4.5 / 26...39	4...6 / 35...53

## Power consumption

	TCMS32S	TCMS32H	TCMS63S, 63H	TCMS100S, 100H
Total power loss Pv				
Circuit breaker at rated load operating temperature	[W] In = 0.16~1.6A : 4.4 In = 2.5~26A : 7.4 In = 32A : 4.0	In = 0.16~1.6A : 4.4 In = 2.5~26A : 7.4 In = 32A : 4.0	In = 10~22A : 10.2 In = 26~63A : 9.7	In = 17~32A : 15 In = 40~63A : 21.8 In = 75~100A : 17.8

## Mounting

35mm DIN rail for TCMS32~63

35mm or 75mm DIN rail for TCMS100

- use 15mm depth for 35mm DIN rail

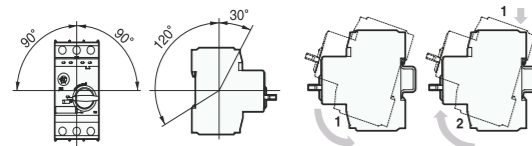

Operating positions

DIN rail mounting

## Environment

Ambient air temperature

storage: - 50...+ 80 °C

operation: - 20...+ 60 °C

Ambient temperature compensation : - 20...+ 60 °C

Maximum operating altitude: 2000m

Protection degree: IP20

Shock resistance: 25g

Vibration resistance: 5~150Hz

## Caution for thermal adjustments

- Keep the setting range as shown below.
- Moving counterclockwise out of the setting range may cause the damage of the device.
- Calibration by ambient air temperature

A: set to one point lower	Calibrated automatically	B: set to one point higher
-20°C	-5°C	+40°C
		+60°C

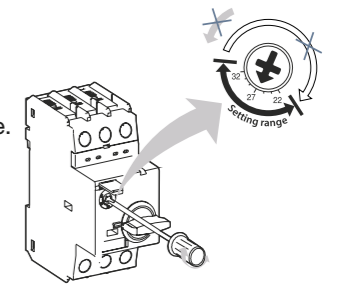

Dial setting method

In case of using out of the standard air temperature range (-5°C~+40°C) it needs to be calibrated by one point

## Auxiliaries

	Auxiliary contacts for front mounting TFX...	Auxiliary contacts for left side mounting TLX...	Alarm switch for left side mounting TLA...
Rated thermal current / th			
at 40°C ambient temperature	[A] 5	10	10
at 60°C ambient temperature	[A] 3	6	6
Contact class coordination according to NEMA (UL/CSA-Standards)	AC A600 DC Q300	A600 Q300	A600 Q300
Back-up fuses gG, gL	[A] 16	16	16
Rated supply current	[V] -	240	24
AC-15:	[A] -	3	6
DC-13:	[V] 24	220	24
	[A] 1	0.1	2
Weight (g)	18	30	40
Terminal parts			
Screwdriver		Pozidriv size 2	
Single-core	1.conductor [mm] / [AWG] 0.5...2.5 / 20...14	0.5...2.5 / 20...14	0.5...2.5 / 20...14
2.conductor	[mm] / [AWG] -	0.5...2.5 / 20...14	0.5...2.5 / 20...14
Standard	1.conductor [mm] / [AWG] 0.5...4 / 20...10	0.5...4 / 20...10	0.5...4 / 20...10
2.conductor	[mm] / [AWG] 0.75...2.5 / 18...14	0.75...2.5 / 18...14	0.75...2.5 / 18...14
Tightening torque	[Nm] / [lb-in] 0.8...1.2 / 7...10	0.8...1.2 / 7...10	0.8...1.2 / 7...10

## General Data

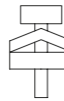
	Undervoltage release for right side mounting <b>TRU...</b>	Undervoltage release with 2 auxiliary contacts for right side mounting <b>TRUX...</b>	Shunt release for right side mounting <b>TRS...</b>
Actuating voltage			
Pull-in	0.7...1.1×Us	0.85...1.1×Us	0.85...1.1×Us
Drop-out		0.7...0.35×Us	0.7...0.35×Us
Rated control voltage			
min.:	24V 50Hz / 28V 60Hz	24V 50Hz / 28V 60Hz	24V 50Hz / 28V 60Hz
max.:	415~440V 50Hz / 460~480V 60Hz	415~440V 50Hz / 460~480V 60Hz	415~440V 50Hz / 460~480V 60Hz
Coil rating			
Pull-in	8.5VA, 6W	8.5VA, 6W	8.5VA, 6W
Hold	3VA, 1.2W	3VA, 1.2W	3VA, 1.2W
Opening time (ms)	-	20	20
Weight (g)	18	30	40
Terminal parts			
			
Screwdriver		Pozidriv size 2	
Single-core	1.conductor [mm] / [AWG]	0.5...2.5 / 20...14	
	2.conductor [mm] / [AWG]	0.5...2.5 / 20...14	
Standard	1.conductor [mm] / [AWG]	0.5...4 / 20...10	
	2.conductor [mm] / [AWG]	0.75...2.5 / 18...14	
Tightening torque	[Nm] / [lb-in]	0.8...1.2 / 7...10	

## Installation of auxiliaries

Be sure to turn off the main switch of TCMS before any other action.



### TCMS-32S/H/HI

To install TFX remove the cover first.

- 2 each of TLX can be installed together.
- Only one of auxiliaries among TRU, TRS and TRUX can be mounted on the right side of TCMS.
- Do not give trip signal to TRS longer than 10 sec.
- Refer to the possible combination chart for the mounting of TLX, TLA and TLAM on left side of TCMS.

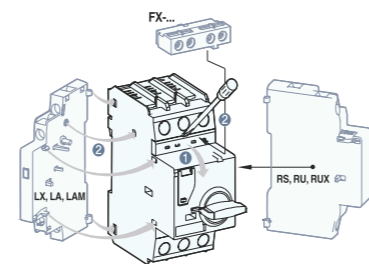

- Push the trip button before installation of TLAM
- Remove the indicated part in the fig. before the additional installation of TLX

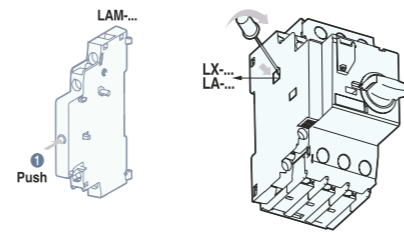

### Separation of auxiliaries from TCMS

- Be sure to turn off the main switch of TCMS before the separation.
- Push softly the separation button on the side of the auxiliary and pull it.

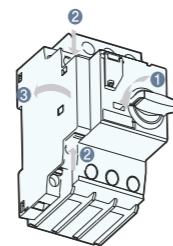

### TCMS-63, 100S/H/HI

To install TFX remove the cover first.

- 2 each of TLX can be installed together. (only 1 each for TCMS-63)
- Only one of auxiliaries among TRU, TRS and TRUX can be mounted on the right side of TCMS.
- Do not give trip signal to TRS longer than 10 sec.
- Refer to the possible combination chart for the mounting of TLX, TLA and TLAM on left side of TCMS.

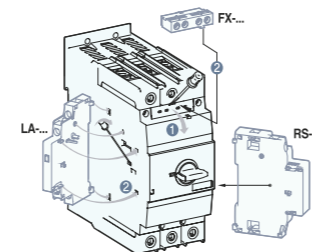

- Remove the indicated part of TCMS-63 and TCMS 100 as shown in the fig. before the installation of TLA

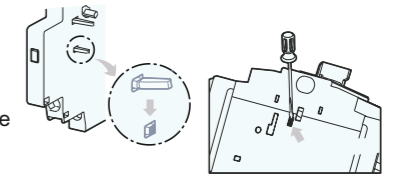

- Do not install TLA in the status of TRIP of TCMS-100



- Remove the indicated part as shown in the above fig. before the additional installation of TLX

### Separation of auxiliaries from TCMS

- Be sure to turn off the main switch of TCMS before the separation.
- Push softly the separation button on the side of the auxiliary and pull it.

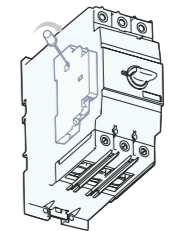

### Installation of auxiliaries

#### How to Install and reset TRUX

##### Installing

1. Check if the trip button of TRUX is "UP". If not, push the side lever ① to come it up.
2. Fit the both lower hooks ② into the TCMS.
3. Rotate the handle of TCMS to the 20 to 30 degree ③ to ON direction and keep it.
4. Fit the both upper hooks ④ into the TCMS
5. Input power to the TRUX
6. Turn ON the handle of TCMS

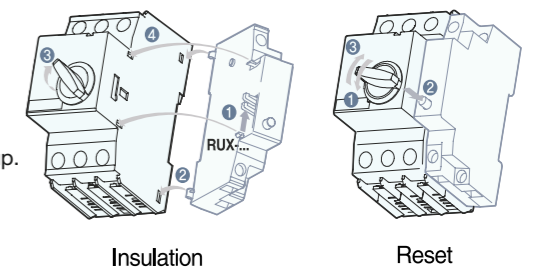

Insulation

Reset

##### Resetting

The trip button of TRUX does not come "UP" in the event of tripping due to undervoltage. To turn ON the TCMS after the tripping

- ① Turn OFF the TCMS and check if the trip button of TRUX comes "UP"
- ② Push the trip button
- ③ Turn ON the TCMS

Insulation barrier

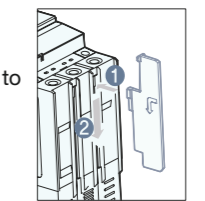

\*Only for TCMS-100

Dial cover

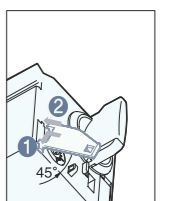

\*For all TCMS

### Combination with mini contactors

Adaptor	TCMS	+ Contactor Model
TDA-16SA	TCMS-32S	+ TCI 06~16
TDA-16SD	TCMS-32S	+ TCI 06~16
TDA-16HA	TCMS-32H	+ TCI 06~16
TDA-16HD	TCMS-32H	+ TCI 06~16

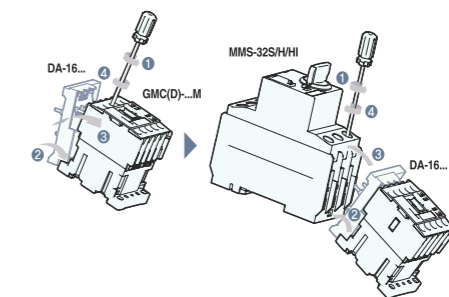

### Installation of auxiliaries

Please read this chart completely before installing the auxiliaries. Improper combination can cause electric failure or accident.

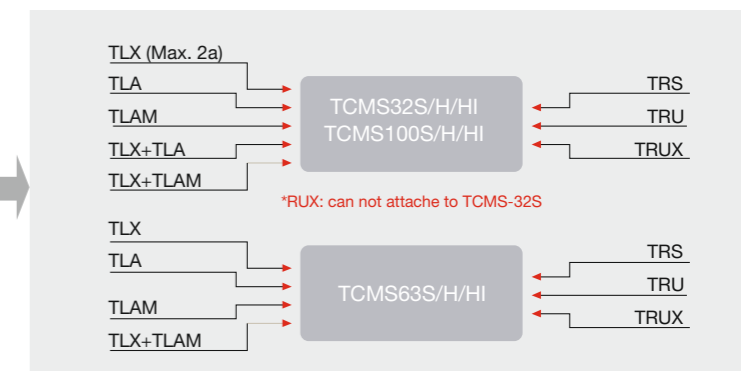

## General Data

### ● E-Handle

#### Structure

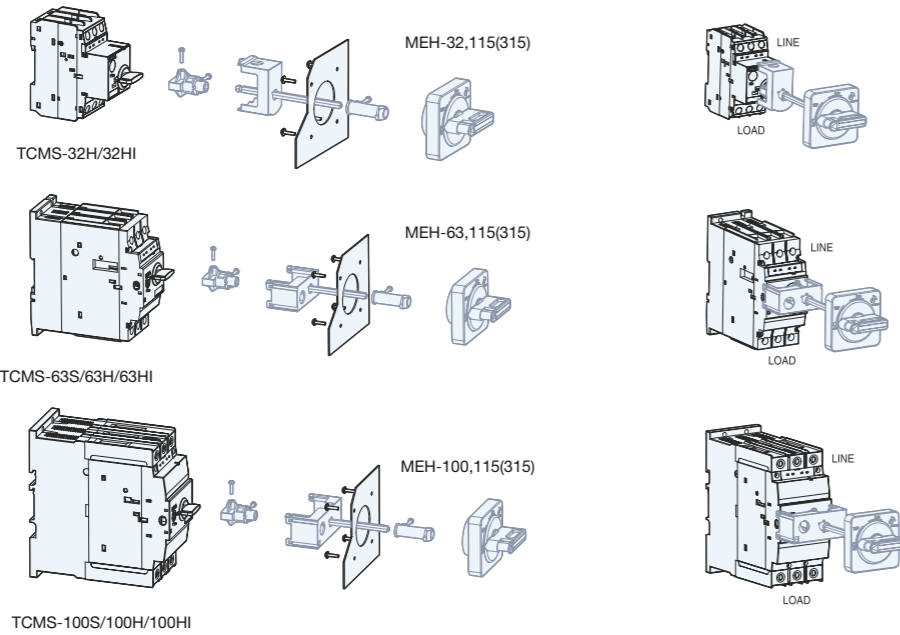

#### Locking Device

When opening the panel door at ON position

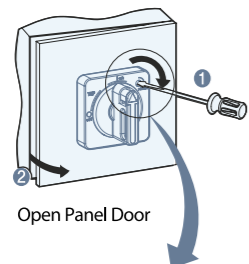

Open Panel Door

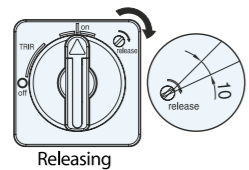

Releasing

Locking  
Installation at OF, OFF position

1 Setting to regular position through turning the handle

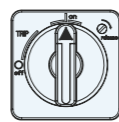

On Position  
(Vertical State)

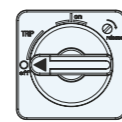

Off Position  
(Horizontal State)

2 Pushing



3 Locking

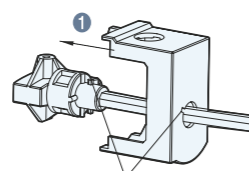
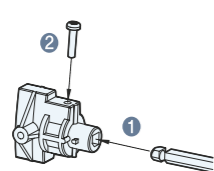
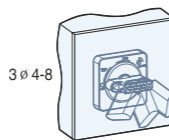

Projection should be passed through the hole when assembling

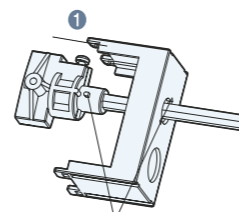

Projection should be passed through the hole when assembling

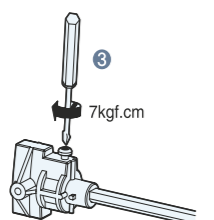

MEH-32/63/100

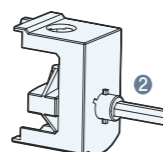

MEH-32

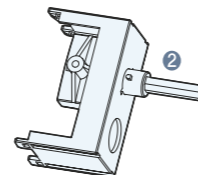

MEH-63/100

### ● E-Handle

#### Installation

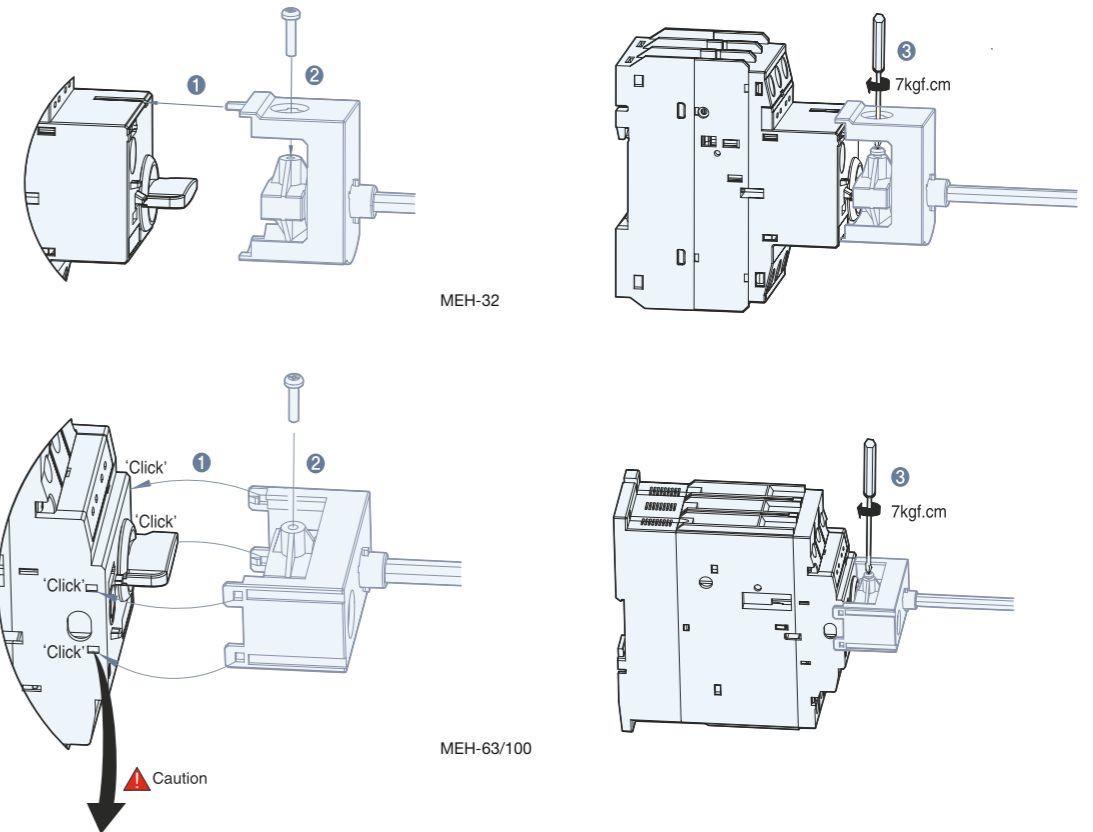

#### Restricted fact of Assembling

Assembling is available for TCMS-63/100 with 4 holes on the main cover which is produced after June, 2007 base on manufacturing date.

#### Operating Test

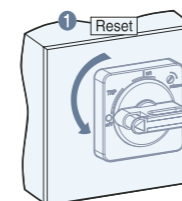

**\*Caution**  
If trying to open the door at ON or Trip position, locking knob can be damaged.

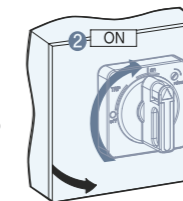

At On position  
Panel door can not be opened

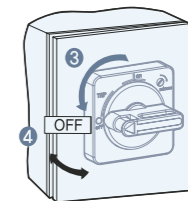

At Trip position  
Panel door can not be opened.  
At Off position  
Panel door can be opened

## General Data

### Cutting off the shaft & applying the handle

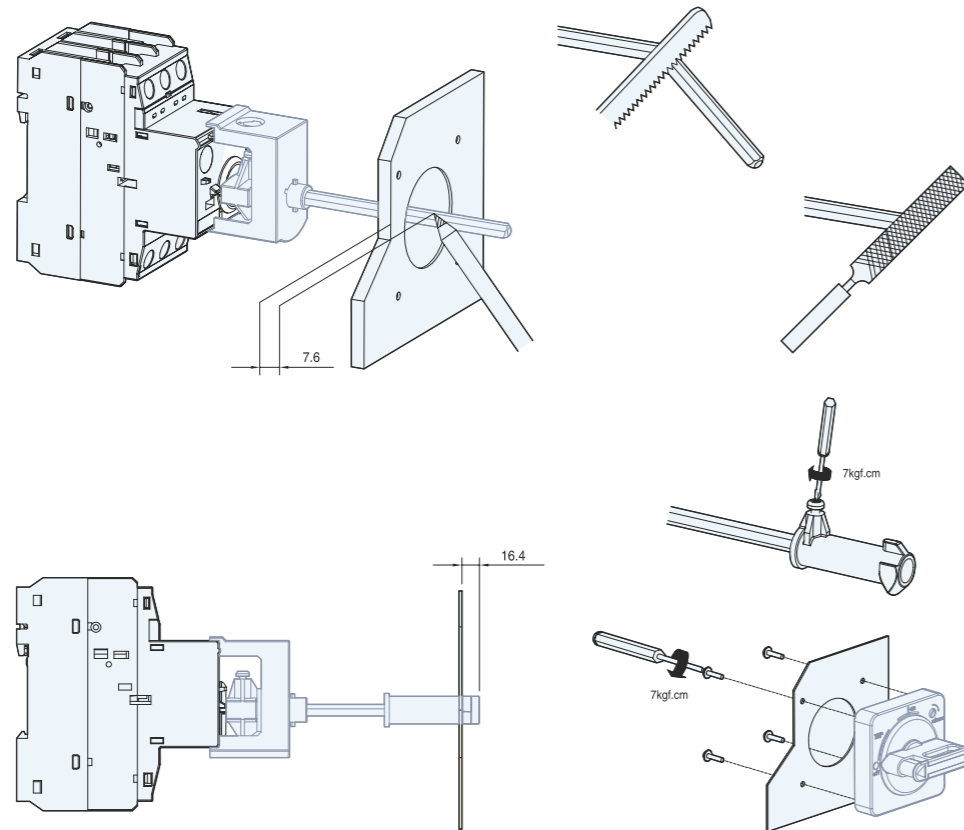

### ● Enclosure

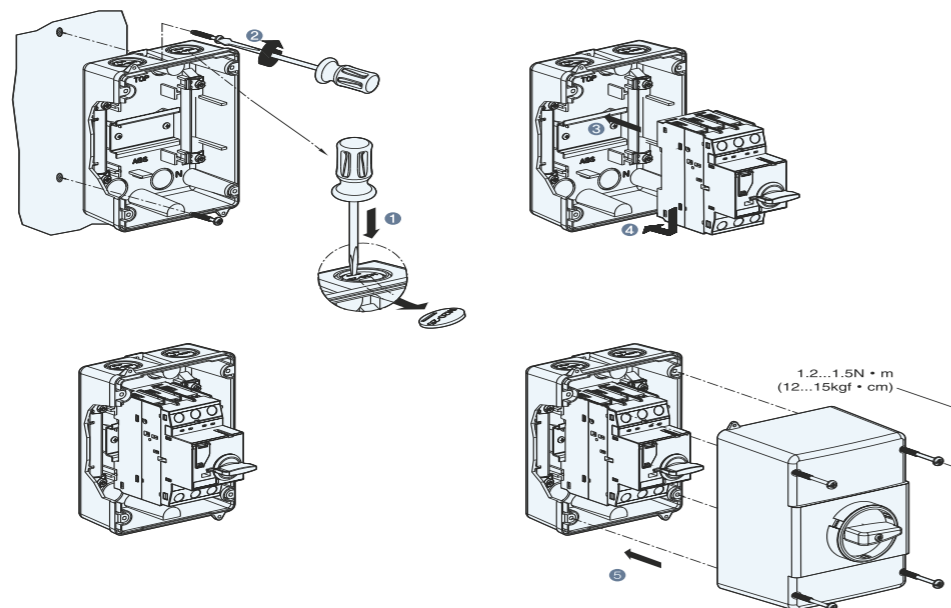

## Manual Motor Controller (UL508, CSA, C22.2)

- Combination Motor Controller
- Group Installation
- Type E Starter

### ● TCMS 32S

Rated operational current I <sub>e</sub> [A]		0.16	0.25	0.4	0.63	1	1.6	2.5	4	6	8	10	13	17	22	26	32	
Max. short-circuit current																		
240V	[kA]	100	100	100	100	100	100	100	100	100	100	50	50	40	30	30	20	
480V	[kA]	50	50	50	50	50	50	50	50	25	25	10	10	10	10	7.5	7.5	
600V	[kA]	10	10	10	10	10	10	10	5	5	5	5	5	5	5	5	5	
Motor load																		
1 Phase	115V	[HP]	-	-	-	-	-	-	1/8	1/4	1/3	1/2	1/2	1	1.5	2	2	
	230V	[HP]	-	-	-	-	-	1/10	1/6	1/3	1/2	1	1.5	2	3	3	3	
3 Phase	200V	[HP]	-	-	-	-	-	-	1/2	3/4	1	2	2	3	3	5	7.5	7.5
	230V	[HP]	-	-	-	-	-	-	1/2	3/4	1.5	2	3	3	5	7.5	7.5	10
	460V	[HP]	-	-	-	-	-	3/4	1	2	3	5	5	7.5	10	15	15	20
	575V	[HP]	-	-	-	-	1/2	3/4	1.5	3	5	5	7.5	10	15	20	20	30
Maximum rated current of fuse or breaker		[A]	1	1	1	1	3	6	10	15	20	30	40	50	60	80	100	125
		[A]	15	15	15	15	15	15	15	20	30	40	50	60	80	100	125	

### ● TCMS 32H

Rated operational current I <sub>e</sub> [A]		0.16	0.25	0.4	0.63	1	1.6	2.5	4	6	8	10	13	17	22	26	32	
Max. short-circuit current																		
240V	[kA]	100	100	100	100	100	100	100	100	100	100	100	100	100	100	100	100	
480V	[kA]	50	50	50	50	50	50	50	50	50	50	50	50	50	50	50	50	
600V	[kA]	10	10	10	10	10	10	10	10	10	10	10	10	10	10	10	10	
Motor load																		
1 Phase	115V	[HP]	-	-	-	-	-	-	1/8	1/4	1/3	1/2	1/2	1	1.5	2	2	
	230V	[HP]	-	-	-	-	-	1/10	1/6	1/3	1/2	1	1.5	2	3	3	3	
3 Phase	200V	[HP]	-	-	-	-	-	-	1/2	3/4	1	2	2	3	3	5	7.5	7.5
	230V	[HP]	-	-	-	-	-	-	1/2	3/4	1.5	2	3	3	5	7.5	7.5	10
	460V	[HP]	-	-	-	-	-	3/4	1	2	3	5	5	7.5	10	15	15	20
	575V	[HP]	-	-	-	-	1/2	3/4	1.5	3	5	5	7.5	10	15	20	20	30
Max. fuse size		[A]	1	1	1	1	3	6	10	15	20	30	40	50	60	80	100	125
Max. breaker size		[A]	15	15	15	15	15	15	15	20	30	40	50	60	80	100	125	

### ● TCMS 63H

Rated operational current I <sub>e</sub> [le]		10	13	17	22	26	32	40	50	63	
Max. short-circuit current											
240V	[kA]	100	100	100	100	100	100	100	100	100	
480V	[kA]	50	50	50	50	50	50	50	50	50	
600V	[kA]	10	10	10	10	10	10	10	10	10	
Motor load											
1 Phase	115V	[HP]	1/2	1/2	1	1.5	2	2	3	3	5
	230V	[HP]	1.5	2	3	3	3	5	7.5	10	10
3 Phase	200V	[HP]	2	3	3	5	7.5	7.5	10	15	20
	230V	[HP]	3	3	5	7.5	7.5	10	10	15	20
	460V	[HP]	5	7.5	10	15	15	20	30	30	40
	575V	[HP]	7.5	10	15	20	20	30	30	40	60
Max. fuse size		[A]	40	50	60	80	100	125	150	200	250
Max. breaker size		[A]	40	50	60	80	100	125	150	200	250



### ● TCMS 100H

Rated operational current I <sub>e</sub> [le]		17	22	26	32	40	50	63	75	90	100	
Max. short-circuit current												
240V	[kA]	100	100	100	100	100	100	100	100	100	100	
480V	[kA]	50	50	50	50	50	50	50	50	50	50	
600V	[kA]	10	10	10	10	10	10	10	10	10	10	
Motor load												
1 Phase	115V	[HP]	1	1.5	2	2	3	3	5	5	7.5	10
	230V	[HP]	3	3	3	5	7.5	10	10	15	20	20
3 Phase	200V	[HP]	3	5	7.5	7.5	10	15	20	20	25	30
	230V	[HP]	5	7.5	7.5	10	10	15	20	25	30	30
	460V	[HP]	10	15	15	20	30	30	40	50	60	75
	575V	[HP]	15	20	20	30	30	40	60	60	75	100
Max. fuse size		[A]	60	80	100	125	150	200	250	300	350	400
Max. breaker size		[A]	60	80	100	125	150	200	250	300	350	400

## IEC Performance Data

Type		TCMS 32S, 32H	TCMS 63H	TCMS 100H
<b>Rated insulation voltage</b>	IEC, IS/UL V	690 / 600	690 / 600	690 / 600
<b>Rated impulse withstand voltage</b>				
Uimp/Pollution degree		6kV / 3	8kV / 3	8kV / 3
<b>Rated frequency</b>		50 / 60 Hz	50 / 60 Hz	50 / 60 Hz
<b>Utilization category:</b>				
IEC 947-2, IS 13947-2 (Circuit breaker)		Cat. A	Cat. A	Cat. A
IEC 947-4-1, IS 13947-4-1 (Motor starter)		AC 3	AC 3	AC 3
<b>Life span</b>				
Mechanical / Electrical (I <sub>e</sub> max.)	Operations	100,000 / 100,000	50,000 / 25,000	50,000 / 25,000
<b>Switching frequency</b>	Ope./h	25	25	25
<b>Ambient temperature</b>				
	Storage °C	-50 ~ +80	-50 ~ +80	-50 ~ +80
	Operation °C	-20 ~ +60	-20 ~ +60	-20 ~ +60
<b>Operation altitude</b>	m	Up to 2000 (6500 Feet)	Up to 2000 (6500 Feet)	Up to 2000 (6500 Feet)
<b>Protection class</b>		IP 20	IP 20	IP 20
<b>Resistance to shock</b>	g	25	25	25
<b>Resistance to vibration</b>	Hz	5 ~ 150	5 ~ 150	5 ~ 150
<b>Rated thermal current I<sub>th</sub></b>				
IEC up to 60°C ambient temperature	[A]	0.1 ... 32	6 ... 63	11 ... 100
<b>Overload protection</b>				
		Available	Available	Available
<b>Ambient temperature compensation</b>				
		-20 ~ +60	-20 ~ +60	-20 ~ +60
<b>Phase-failure protection</b>				
		Available	Available	Available
<b>Trip class</b>	IEC 60947-4-1	10	10	10
<b>Magnetic release</b>		13 × I <sub>n</sub> <sup>#</sup>	13 × I <sub>n</sub> <sup>#</sup>	13 × I <sub>n</sub> <sup>#</sup>
<b>Total power loss P<sub>v</sub></b>				
Circuit breaker at rated load	[W]	I <sub>n</sub> = 0.16~4A : 9.8	I <sub>n</sub> = 10~22A : 16	I <sub>n</sub> = 17~63A : 17
Operating temperature		I <sub>n</sub> = 6~26A : 7.5	I <sub>n</sub> = 26~63A : 12	I <sub>n</sub> = 75~100A : 21
		I <sub>n</sub> = 32A : 4.5		
<b>Terminal capacity</b>				
Single-core	1.conductor [mm <sup>2</sup> ] / [AWG]	1...10 / 18...8	0.75...35 / 18...2	2.5...70 / 12...2/0
	2.conductor [mm <sup>2</sup> ] / [AWG]	1...6 / 18...10	0.75...25 / 18...4	2.5...50 / 12...1/0
Stranded	1.conductor [mm <sup>2</sup> ] / [AWG]	1...6 / 18...10	0.75...35 / 18...2	2.5...70 / 12...2/0
	2.conductor [mm <sup>2</sup> ] / [AWG]	1...6 / 18...10	0.75...25 / 18...4	2.5...50 / 12...1/0
Flexible	1.conductor [mm <sup>2</sup> ] / [AWG]	1...6 / 18...10	0.75...25 / 18...4	2.5...50 / 12...1/0
	2.conductor [mm <sup>2</sup> ] / [AWG]	0.75...4 / 18...10	0.75...16 / 18...6	2.5...35 / 10...2
Tightening torque	[Nm] / [lb-in]	0.8...2.5 / 7...22	3...4.5 / 26...39	4...6 / 35...53

Note: # In = Max. rated operational current I<sub>e</sub>

Accessories	Auxiliary contacts for front mounting TFX...	Auxiliary contacts for left side mounting TLX...	Alarm switch for left side mounting TLA...
<b>Rated thermal current / th</b> at 40°C / 60°C ambient temperature	[A] 5 / 3	10 / 6	10 / 6
<b>Back-up fuses gG, gL</b>	[A] 16	16	16
<b>Rated supply current</b>	AC-15: [V] / [A] 24 / 3, 240 / 2	24 / 6, 240 / 4	24 / 6, 240 / 4
	DC-13: [V] / [A] 24 / 1, 220 / 0.1	24 / 2, 220 / 0.25	24 / 2, 220 / 0.25

Accessories	Undervoltage release for right side mounting TRU...	Undervoltage release with 2 auxiliary contacts for right side mounting TRUX...	Shunt release for right side mounting TRS...
<b>Actuating voltage</b>			
Pull-in	0.85...1.1 × Us	0.85...1.1 × Us	0.7...1.1 × Us
Drop-out	0.7...0.35 × Us	0.7...0.35 × Us	
<b>Coil rating</b>			
Pull-in	8.5VA, 6W	8.5VA, 6W	8.5VA, 6W
Hold	3VA, 1.2W	3VA, 1.2W	3VA, 1.2W
On-Time	100%	100%	100%
<b>Terminal capacity for Accessories</b>			
1.conductor [mm <sup>2</sup> ] / [AWG]	Single-core 0.5...2.5 / 20...14	Flexible 0.5...4 / 20...10	
2.conductor [mm <sup>2</sup> ] / [AWG]	0.5...2.5 / 20...14	0.75...2.5 / 18...14	

Type	Rated operational current (I <sub>e</sub> )	Thermal release Adjustment range (A)	240V * 230V #		415V * 400V #		460V * 440V #		525V * 500V #		690V * 600V #	
			I <sub>cu</sub>	I <sub>cs</sub>	I <sub>cu</sub>	I <sub>cs</sub>	I <sub>cu</sub>	I <sub>cs</sub>	I <sub>cu</sub>	I <sub>cs</sub>	I <sub>cu</sub>	I <sub>cs</sub>
TCMS-32S	0.16	0.1~0.16	100	100	100	100	100	100	100	100	100	100
	0.25	0.16~0.25	100	100	100	100	100	100	100	100	100	100
	0.4	0.25~0.4	100	100	100	100	100	100	100	100	100	100
	0.63	0.4~0.63	100	100	100	100	100	100	100	100	100	100
	1	0.63~1	100	100	100	100	100	100	100	100	100	100
	1.6	1~1.6	100	100	100	100	100	100	100	100	3	3
	2.5	1.6~2.5	100	100	100	100	100	100	50	38	3	3
	4	2.5~4	100	100	100	100	50	38	15	11	3	3
	6	4~6	100	100	100	100	15	11	10	8	3	3
	8	5~8	100	100	100	100	15	11	10	8	3	3
	10	6~10	100	100	50	38	15	11	6	5	3	3
	13	9~13	100	100	50	38	10	8	6	5	3	3
	17	11~17	100	100	25	19	10	8	6	5	3	3
22	14~22	50	38	20	15	10	8	6	5	3	3	
26	18~26	40	30	15	11	8	6	6	5	3	3	
32	22~32	40	30	15	11	8	6	6	5	3	3	
TCMS-63H	40	28~40	100	100	50	50	35	27	10	8	5	4
	50	34~50	100	100	50	50	35	27	10	8	5	4
	63	45~63	100	100	50	50	35	27	10	8	5	4
TCMS-100H	75	55~75	100	100	100	50	50	38	12	9	6	6
	90	70~90	100	100	100	50	50	38	12	9	6	6
	100	80~100	100	100	100	50	50	38	12	9	6	6

Note: \* : Permissible up to 5% over voltage, # : Permissible up to 10% over voltage

gG, gL, only I<sub>cc</sub>>I<sub>cu</sub>  
(\* = No back up fuse required)

### TCMS-32S

Rated operational current I <sub>e</sub>	[A]	0.16	0.25	0.4	0.63	1	1.6	2.5	4	6	8	10	13	17	22	26	32
230/240V	[A]	*	*	*	*	*	*	*	*	*	*	*	*	*	125	125	125
400/415V	[A]	*	*	*	*	*	*	*	*	*	*	80	80	100	100	100	100
440/460V	[A]	*	*	*	*	*	*	*	50	50	63	63	80	80	100	100	100
500V	[A]	*	*	*	*	*	*	50	40	50	63	63	80	80	80	80	80
690V	[A]	*	*	*	*	*	20	35	40	50	63	63	63	63	63	63	63

### TCMS-32H, 32HI

Rated operational current I <sub>e</sub>	[A]	0.16	0.25	0.4	0.63	1	1.6	2.5	4	6	8	10	13	17	22	26	32
230/240V	[A]	*	*	*	*	*	*	*	*	*	*	*	*	*	*	*	*
400/415V	[A]	*	*	*	*	*	*	*	*	*	*	*	*	100	125	125	125
440/460V	[A]	*	*	*	*	*	*	*	*	*	80	80	80	80	100	100	100
500V	[A]	*	*	*	*	*	*	*	*	*	63	80	80	80	80	80	80
690V	[A]	*	*	*	*	*	*	35	40	50	63	63	63	63	63	63	63

### TCMS-63H, 63HI

Rated operational current I <sub>e</sub>	[A]	10	13	17	22	26	32	40	50	63
230/240V	[A]	*	*	*	*	*	*	*	*	*
400/415V	[A]	*	*	100	125	125	125	160	160	160
440/460V	[A]	100	100	100	125	125	125	125	125	160
500V	[A]	100	100	100	100	100	100	100	100	100
690V	[A]	63	63	63	80	80	80	80	80	80

### TCMS-100H, 100HI

Rated operational current I <sub>e</sub>	[A]	17	22	26	32	40	50	63	75	90	100
230/240V	[A]	*	*	*	*	*	*	*	*	*	*
400/415V	[A]	*	*	*	*	*	*	*	*	*	*
440/460V	[A]	125	125	125	160	160	160	200	200	200	200
500V	[A]	100	125	125	125	160	160	160	160	160	160
690V	[A]	80	80	80	80	80	100	100	125	160	160

## Type '2' coordination according to IEC 947-4-1/ IS13947-4-1

- DOL Feeders
- Short-circuit current I<sub>q</sub> = 50kA  
Voltage : 400 / 415V, 50/60Hz

Standard motors AC-3 at 400/415V 1500rpm		Manual motor starter			Contactor	
[kW]	[A]	Circuit breaker Type	Thermal overload release setting range [A]	Magnetic release response current [A]	Type	[A]
-	-	TCMS-32S 0.16A	0.1~0.16	2.08	TC1M06 / TC1M09	6 / 9
0.06	0.2	TCMS-32S 0.25A	0.16~0.25	3.25	TC1M06 / TC1M09	6 / 9
0.09	0.3	TCMS-32S 0.4A	0.25~0.4	5.2	TC1M06 / TC1M09	6 / 9
0.12	0.4	TCMS-32S 0.63A	0.4~0.63	8.19	TC1M06 / TC1M09	6 / 9
0.18	0.6	TCMS-32S 0.63A	0.4~0.63	8.19	TC1M06 / TC1M09	6 / 9
0.25	0.8	TCMS-32S 1A	0.63~1	13	TC1M06 / TC1M09	6 / 9
0.37	1.1	TCMS-32S 1.6A	1~1.6	20.8	TC1M06 / TC1M09	6 / 9
0.55	1.5	TCMS-32S 1.6A	1~1.6	20.8	TC1M06/TC1M09	6 / 9
0.75	1.9	TCMS-32S 2.5A	1.6~2.5	32.5	TC1M12	12
1.1	2.7	TCMS-32S 4A	2.5~4	52	TC1M16	16
1.5	3.6	TCMS-32S 4A	2.5~4	52	TC1M16	16
2.2	5.2	TCMS-32S 6A	4~6	78	TC1M16	16
3	6.8	TCMS-32S 8A	5~8	104	TC1M16	16
4	9	TCMS-32S 10A	6~10	130	TC1M16	16
5.5	11.5	TCMS-32H 13A	9~13	169	TC1M16	16
7.5	15.5	TCMS-32H 17A	11~17	221	TC1M16	16
10	20	TCMS-32H 22A	14~22	286	TC1D25	25
11	22	TCMS-32H 26A	18~26	338	TC1D25	25
15	29	TCMS-32H 32A	22~32	416	TC1D32	32
18.5	35	TCMS-63H 40A	28~40	520	TC1D50	50
22	41	TCMS-63H 50A	34~50	650	TC1D50	50
30	55	TCMS-63H 63A	45~63	819	TC1D65	65
37	67	TCMS-100S 75A	55~75	975	TC1D80	75
-	-	TCMS-100S 90A	70~90	1170	TC1D95	85
45	80	TCMS-100S 100A	80~100	1300	TC1D95	85

### Definition type '2' coordination according to IEC 947-4-1

- The contactor or the starter must not endanger persons or systems in the event of a short-circuit.
- The contactor or the starter must be suitable for further use.
- No damage to the overload relay or other parts may occur with the exception of welding of the contactor or starter contacts provided that these can be easily separated without significant deformation (such as with a screwdriver).

## Type "2" coordination according to IEC947-4-1/ IS13947-4-1

- Star Delta Feeders
- Short-circuit current I<sub>q</sub> = 50kA  
Voltage : 400 / 415V, 50/60Hz

Standard motors AC-3 at 400/415V 1500rpm		Manual motor starter			Contactor	
KW	A	Circuit breaker Type	Thermal overload release setting range A	Magnetic release response current A	Type	A
3	6.8	TCMS-32S 4A	2.5 ~ 4	52	TC1M16/TC1-D18	16/18
4	9	TCMS-32S 6A	4 ~ 6	78	TC1M16/TC1-D18	16/18
5.5	11.5	TCMS-32S 8A	5 ~ 8	104	TC1M16/TC1-D18	16/18
7.5	15.5	TCMS-32S 10A	6 ~ 10	130	TC1-D18	18
10	20	TCMS-32H 13A	9 ~ 13	169	TC1-D18	18
11	22	TCMS-32H 17A	11 ~ 17	221	TC1-D25	25
15	29	TCMS-32H 22A	14 ~ 22	286	TC1-D25	25
18.5	35	TCMS-32H 26A	18 ~ 26	338	TC1-D32	32
22	41	TCMS-32H 22A	22~ 32	416	TC1-D40	40
30	55	TCMS-63H 40A	28~ 40	520	TC1-D40	40
37	67	TCMS-63H 50A	34~ 50	650	TC1-D50	50
45	80	TCMS-63H 50A	34 ~ 50	650	TC1-D50	50
55	97	TCMS-63H 63A	45 ~ 63	819	TC1-D65	65
75	132	TCMS-100S 90A	70 ~ 90	1170	TC1-D95	95
90	160	TCMS-100S 100A	80 ~ 100	1130	TC1-D95	95

## Time/Current characteristic

**TCMS-32AF  
Tripping Curve**

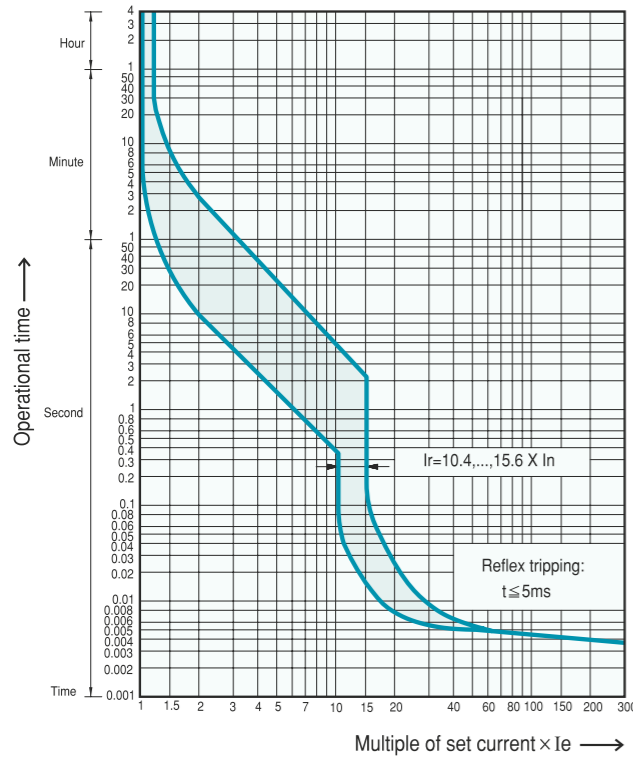

**TCMS-63, 100AF  
Tripping Curve**

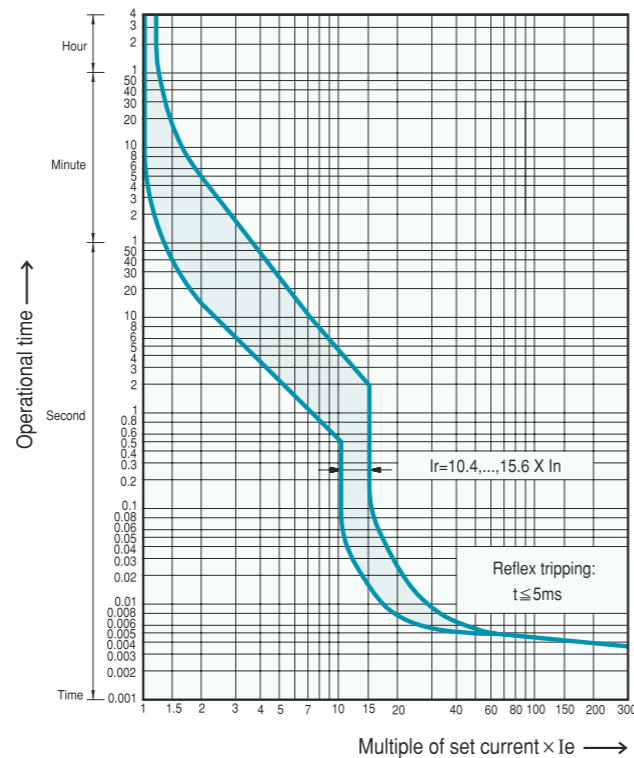

**1. Thermal release trip current:**

The adjustable inverse bimetal trip reliability protects motors against overloads.  
The curve shows the mean operating current at an ambient temperature of 20°C starting from cold.  
Careful testing and setting ensures effective motor protection even in the case of single-phasing.

**2. Magnetic release trip current:**

The instantaneous magnetic trip has a fixed operating current setting.  
This corresponds to 13times the maximum value of setting range, at a lower setting it is correspondingly higher.

**3. Current setting Ie:**

The overload trip corresponds to a thermal overload relay in a motor starter conforming to IEC 947-4-1. If a different value is prescribed (e.g. reduced Ie for cooling medium having a temperature higher than 40°C or a place of installation higher than 2000m above sea level), the setting current is equal to the reduced rated current Ie of the motor.

• TCMS 32H, 32HI

[mm]

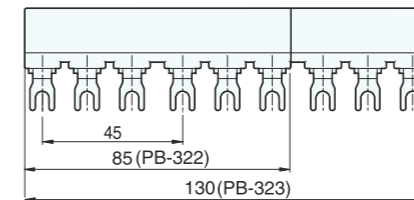
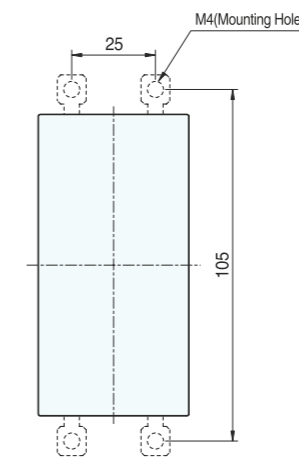
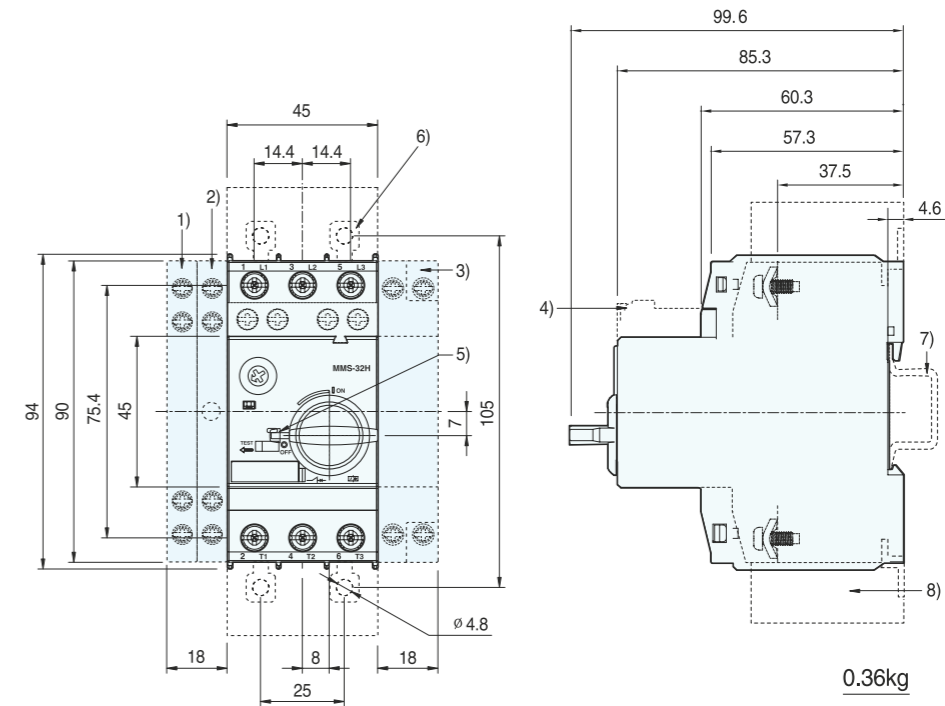

TCMS-32H/HI+PB-32(2,3 Terminal)  
PB-322(2 Terminal), PB-323(3 Terminal)

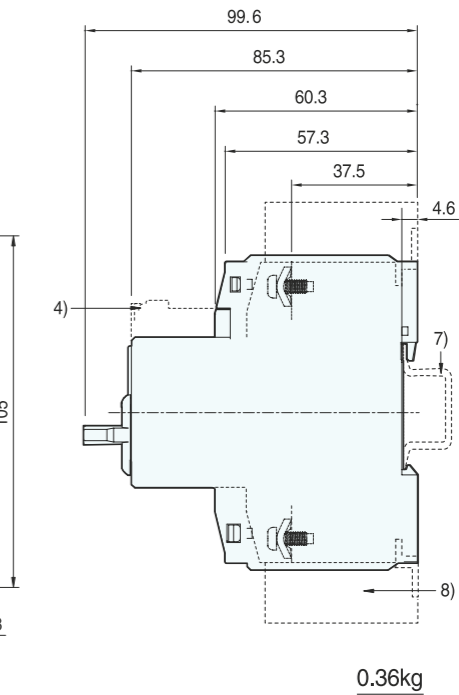

Height of arcing spaces  
(Clearance from earthed parts)

Ue[V]	240	415	460	525	690
[mm]	30	30	30	30	50

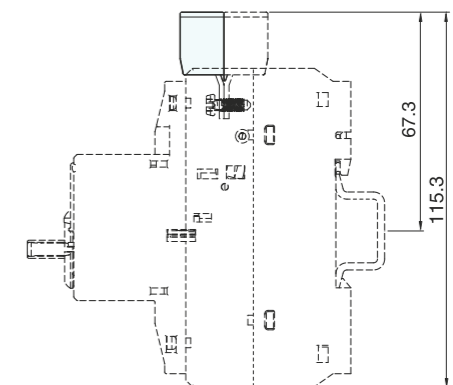

## Dimensions

### ● TCMS

[mm]

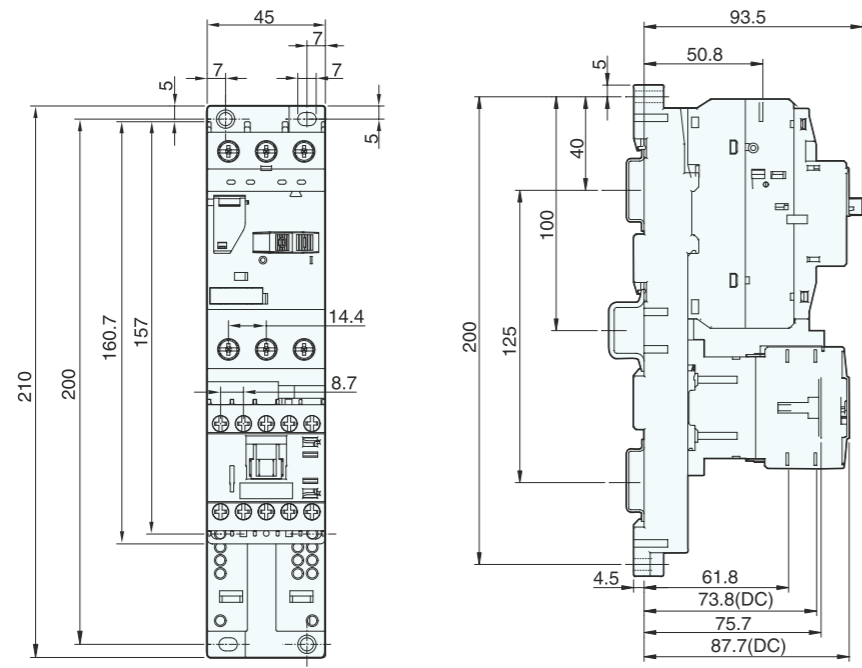

TCMS-32S+TCM06-16

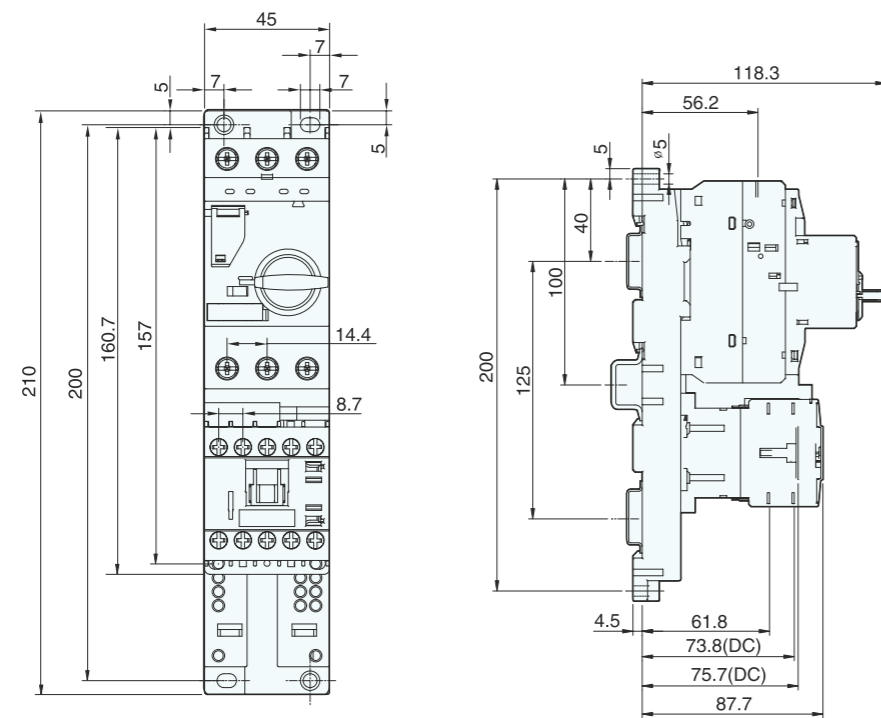

TCMS-32H+TCM06-16

## Dimensions

### ● TCMS 63S, 63H, 63HI

[mm]

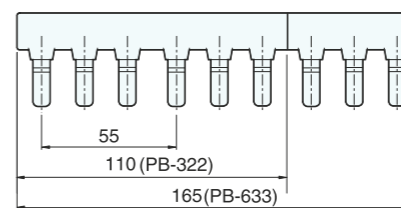
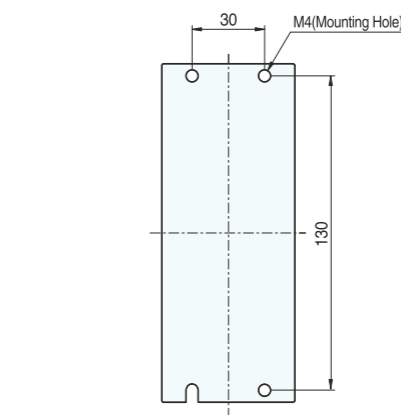
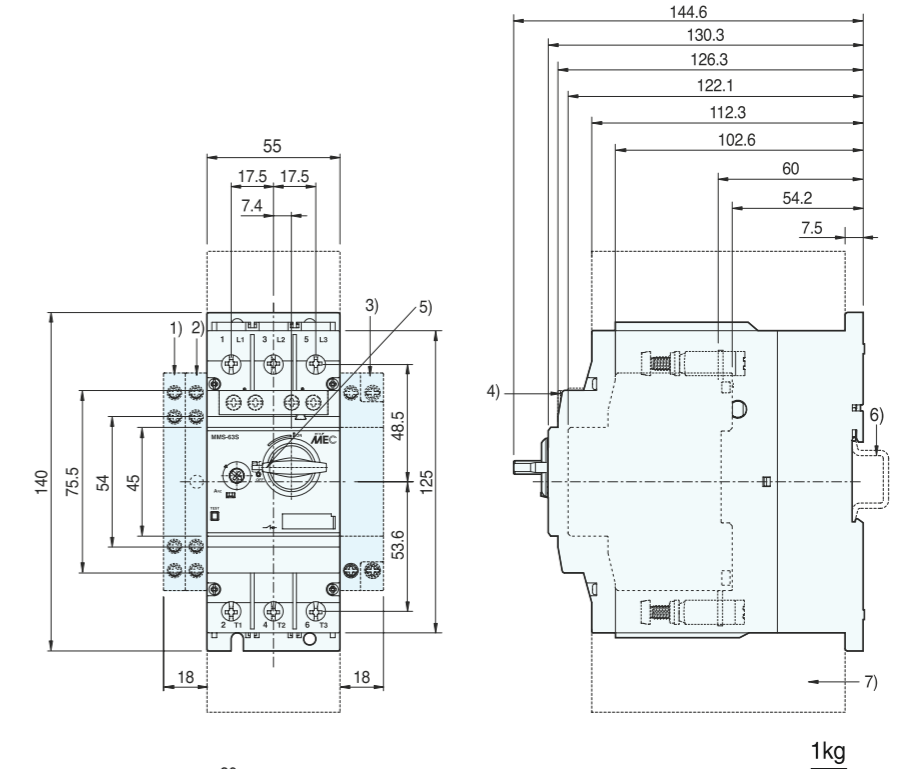

TCMS-63S/H/HI+ PB-63(2,3 Terminal)  
PB-632(2 Terminal), PB-633(3 Terminal)

- 1) Side auxiliary switch
- 2) Side magnetic trip alarm switch
- 3) Side shunt release or Side undervoltage release
- 4) Front auxiliary switch
- 5) Handle lock in OFF position (ø 5mm)
- 6) 35mm standard mounting rail acc. to EN 50 022
- 7) Arcing space

Height of arcing spaces  
(Clearance from earthed parts)

Ue[V]	240	415	460	525	690
[mm]	50	50	50	50	50

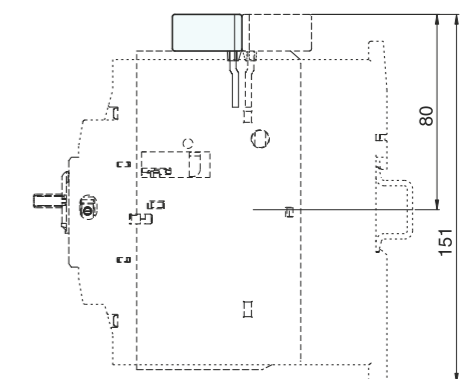



## Dimensions

● TCMS 100S, 100H, 100HI

[mm]

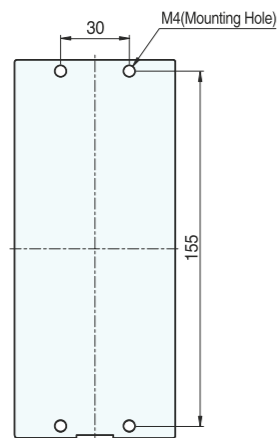
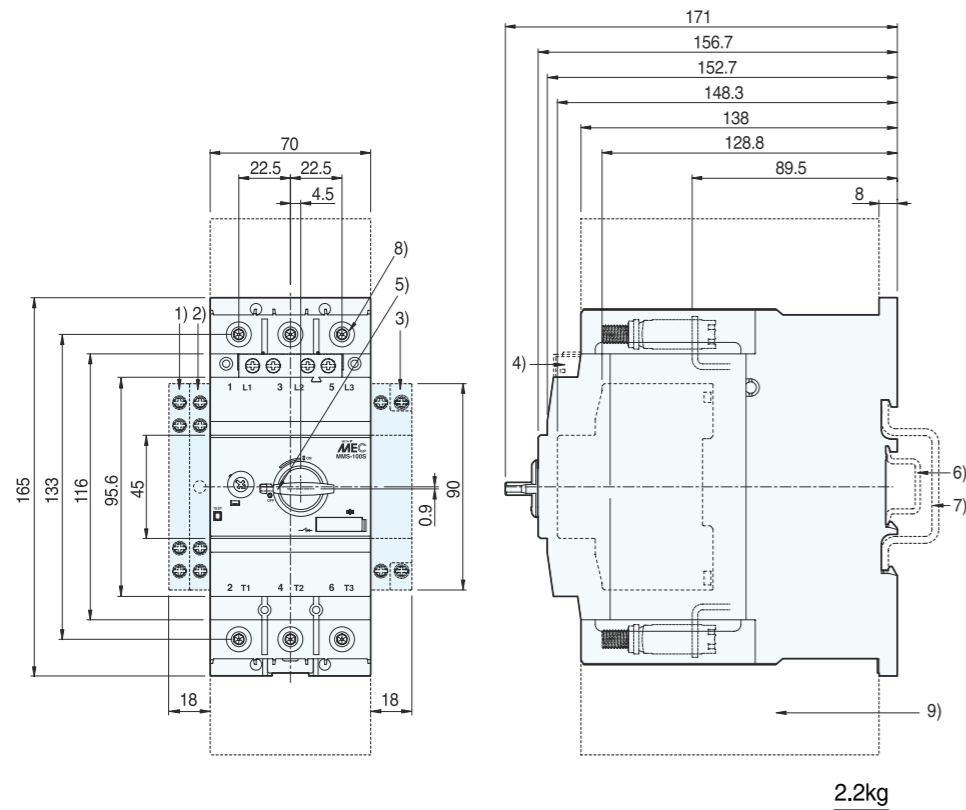

Height of arcing spaces  
(Clearance from earthed parts)

U <sub>e</sub> [V]	240	415	460	525	690
[mm]	50	70	70	110	150

## Dimensions

● E-Handle

[mm]

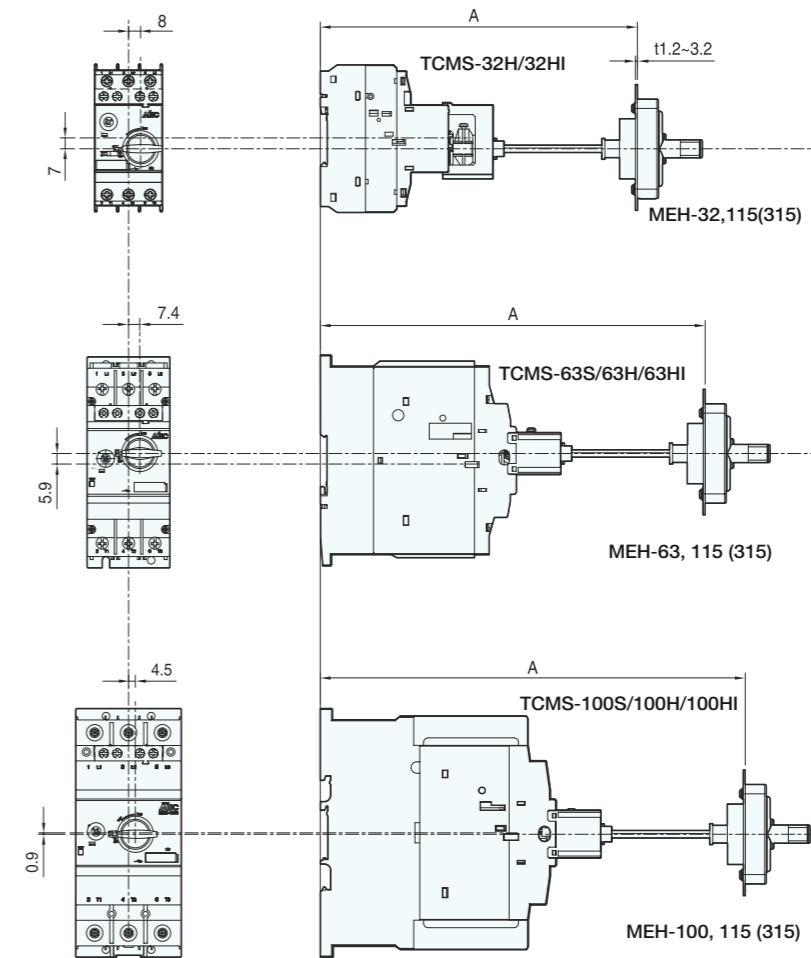

E-Handle Type	A(mm)	TCMS Type
MEH-32, 115	min : 148.6	TCMS-32H/32HI
	max:210.6(Shaft 115mm)	
MEH-32, 315	min : 148.6	TCMS-32H/32HI
	max:410.6(Shaft 315mm)	
MEH-63, 115	min : 193.6	TCMS-63S/63H/63HI
	max:255.6(Shaft 115mm)	
MEH-63, 315	min : 193.6	TCMS-63S/63H/63HI
	max:455.6(Shaft 315mm)	
MEH-100, 115	min : 220	TCMS-100S/100H/100HI
	max:282(Shaft 115mm)	
MEH-100, 315	min : 220	TCMS-100S/100H/100HI
	max:482(Shaft 315mm)	

