

We touch your **electricity** everyday!

## IRIPro -V3

Over current Short circuit & Earth Fault Protection Relay



**IRIPro** Series

Catalog

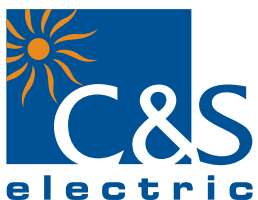

CE

PMD Division

## INDEX

S.No.	Description
1.	Introduction
2.	Features
3.	Application
4.	Hardware
5.	Protection Features
6.	Functional Diagram
7.	Fault Recording
8.	Human Machine Interface
9.	Front Communication
10.	Setting Ranges
11.	Technical Data
12.	Model Description Table
13.	Connection Diagram
14.	Dimensional Details
15.	Panel cut out Details
16.	Ordering Information



## 1) Introduction

IRIPRO Series offers a compact Over-current protection solution for distribution/feeder segment.

IRIPRO Family of protective relays are numeric relays that provides protection and monitoring with reliable and fast protection solution in a single unit with programmable digital outputs.

## 2) Features

- ❖ Three Phase Time Over-current Protection
- ❖ Three Phase Instantaneous Protection
- ❖ Earth Time Over-current and Earth Instantaneous Over Current
- ❖ Circuit Breaker Failure Detection
- ❖ Fault Recorder
- ❖ Output DO Programmable

## 3) Application

The IRIPRO-V3 relays have been designed for controlling, protecting and monitoring industrial, utility distribution networks and substations. They can also be used as part of backup protection scheme for feeders, transformers and generators.

## 4) Hardware

- ❖ Micro Controller Based Numeric Design
- ❖ Measures True RMS with DFT Filter
- ❖ 4 Current Analog Inputs
- ❖ Bright LCD Display
- ❖ 3 Push Button on The Front For MMI
- ❖ 5 LEDs for Annunciation

## 5) Protection Features

- ❖ Three Phase Time Over Current Protection (51)
- ❖ Three Phase Instantaneous Protection (50)
- ❖ Earth Time Over-current (51N)
- ❖ Earth Instantaneous Over-current (50N)
- ❖ Circuit Breaker Failure Protection (50BF)

## 6) Functional Diagram

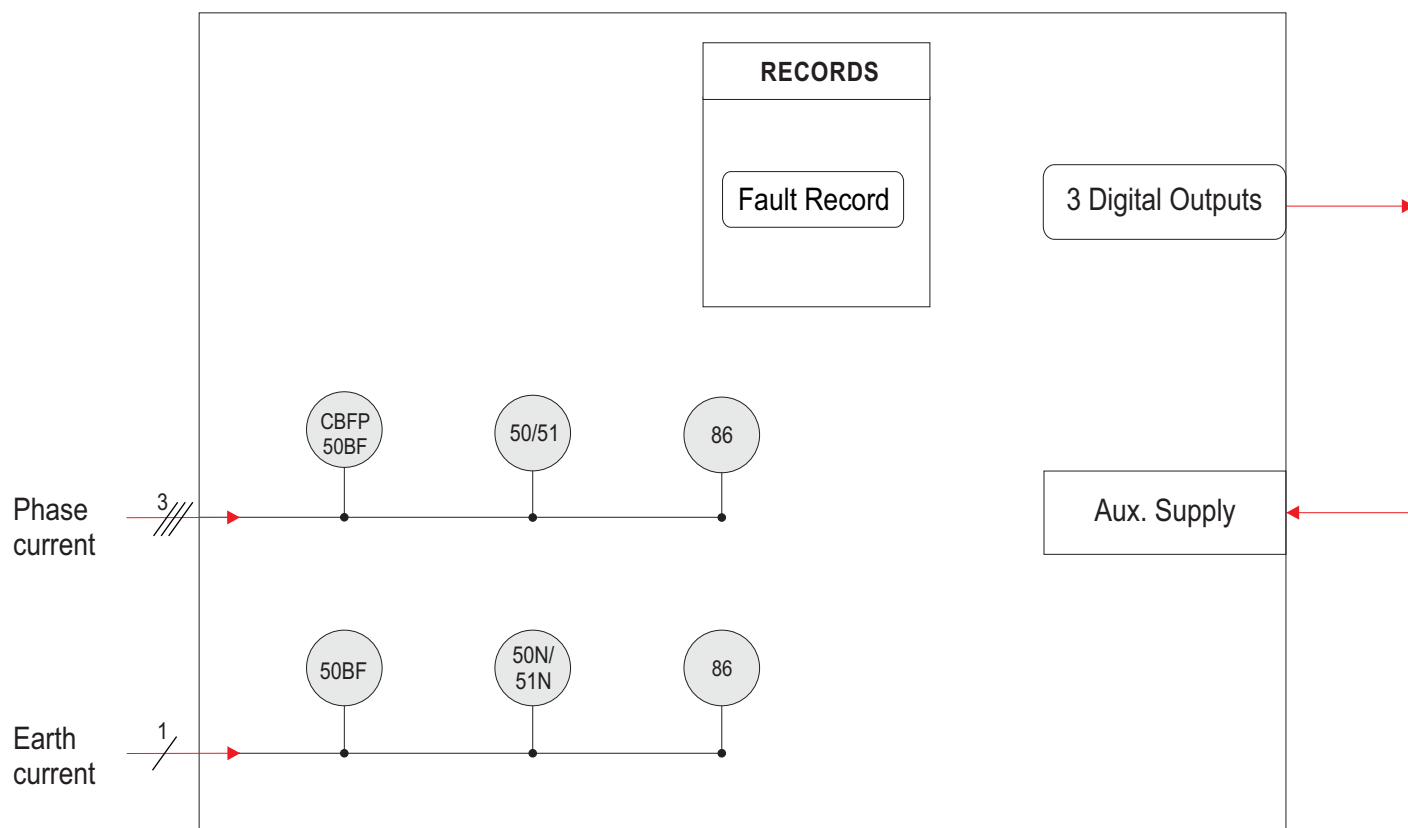

(Figure 1)

### Protection Function

#### Three Phase Over-current Protection (50/51)

The independent two stages are available for phase fault protection. For first stage ( $I>$ ) the user may independently select definite time delay or inverse time delay with different type of curves. The second Hi-Set stage ( $I>>$ ) can be configured with definite time only.

#### Earth Fault Protection (50N/51N)

The independent two stages are available for earth fault protection. For first stage ( $Ie>$ ) the user can select definite time delay or inverse time delay with different type of curves. The second Hi-Set ( $Ie>>$ ) stage can be configured with definite time only.

#### Relay Latching (86)

Relay can be configured to Latch /Unlatch depending on configuration.  
(Latching is possible in presence of Auxiliary supply voltage only)

#### Circuit Breaker Failure Protection (50 BF)

The CB Failure Protection is based on supervision of phase and earth currents after tripping events. The test criterion is whether all phase currents have dropped to less than 5% of  $I_n$  within  $t_{CBFP}$ . If one or more of the phase currents have not dropped to specified current within this time, CB failure is detected and the assigned output relay is activated.

#### Reset Delay

This parameter introduces a delay in opening of relay contacts, when the current goes below the drop out value for over current, short circuit and earth faults. This parameter will not work when manual reset mode is selected.

## 7) Fault Recording

IRIPRO-V3 records last 5 faults in its non volatile memory with it's time stamp. Each record has the following information:

Fault Format

IL1 : 00.00A  
 IL2 : 00.00A  
 IL3 : 00.00A  
 Ie : 00.00A  
 TRIP OC : L1/L2/L3/E  
 TRIP SC : L1/L2/L3/E  
 TRP CBF : CBFP  
 TIM : HH:MM:SEC  
 DAT : DD:MM:YY

Where

[ILx] Magnitude of phase current's.

Ie Magnitude earth fault current's

FLT1 indicates the latest fault.

The user can view the fault record via the front USB interface software (See Figure 2).

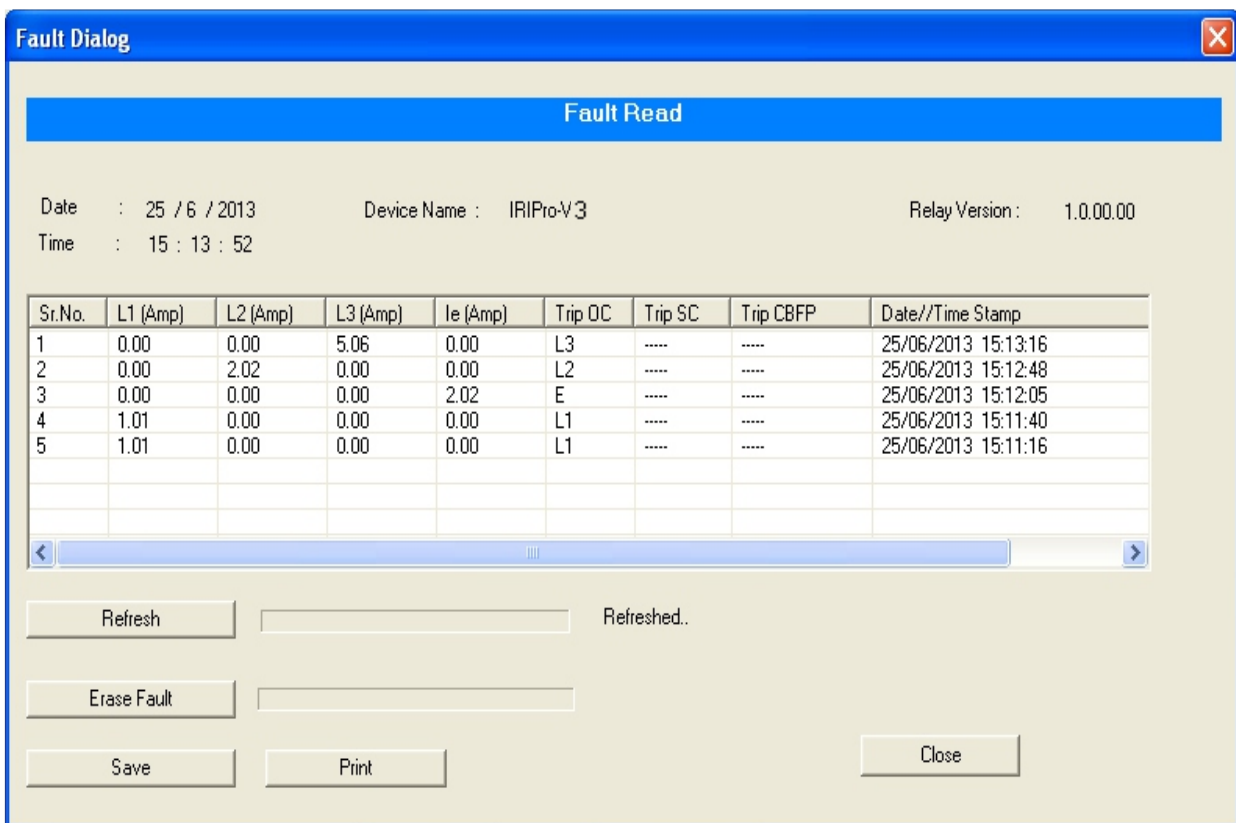

(Figure 2) (Fault Data Recording on PC software)



## Output Contacts

No. of Digital Outputs : 3 (DO1, DO2, DO3)  
 Type of Outputs : Relay  
 Programmable (DO Assignment) : Yes  
 Relay Reset Type : Programmable (Auto/Manual)

## 8) Human Machine Interface

It comprises of bright LCD display

- ❖ Two push switches for setting values of normal tripping characteristics and other operations for local access.
- ❖ One 'RESET/ENTER' push switch.
- ❖ Five LEDs.

Keys	Manual Key
	is used to manual reset (after pressing for 3 sec) and also works as ENTER key.
	is used to scroll in backward direction.
	is used to scroll in forward direction.



(Figure 3) (HMI)



(Figure 4) (HMI)

## 10) Setting Ranges

S. No	Parameter	Display	Setting Range		Step Size	Default Setting
			Min.	Max.		
1	Phase over-current characteristics	P-Char			DEFT/EINV/VINV/ NINV1.3/NINV3.0 NINV0.6	DEFT
2	Earth over-current Characteristics	E-Char			DEFT/EINV/VINV /NINV1.3/NINV3.0/ NINV0.6	DEFT
3	Phase over-current low set pickup setting Phase over-current definite timing Phase over-current inverse timing	I> t> ti>	0.20xI <sub>p</sub> 0.1 Sec 0.01	2.5xI <sub>p</sub> 150 Sec 1.500	0.05xI <sub>p</sub> 0.01Sec 0.005	EXIT 0.10 Sec 0.05
4	Phase over-current hi-set pickup setting Phase over-current hi-set definite timing	I>> t>>	0.5xI <sub>p</sub> 0.03 Sec	25xI <sub>p</sub> 20 Sec	0.5xI <sub>p</sub> 0.01Sec	EXIT 0.10 Sec
5	Earth over-current low set pickup setting Earth over-current low set definite timing Earth over-current low set inverse timing	E> te> tie>	0.05xI <sub>n</sub> 0.03 Sec 0.01	2.5xI <sub>n</sub> 150 Sec 1.500	0.05xI <sub>n</sub> 0.01Sec 0.005	EXIT 0.10 Sec 0.05
6	Earth over-current hi-set pickup setting Earth over-current hi-set definite timing	E>> te>>	0.5xI <sub>n</sub> 0.02 Sec	15xI <sub>n</sub> 20 Sec	0.05xI <sub>n</sub> 0.01 Sec	EXIT 0.10 Sec
7	Circuit Breaker Failure protection definite timing	tCBFP	0.05 Sec	2 Sec	0.01 Sec	EXIT

$$\text{Very Inverse} \quad t = \frac{13.5}{(I/I_s) - 1} \quad t_i \text{ [s]}$$

$$\text{Extremely Inverse} \quad t = \frac{80}{(I/I_s)^2 - 1} \quad t_i \text{ [s]}$$

$$\text{Normal Inverse 3.0/1.3/0.6} \quad t = \frac{0.14/0.061/0.028}{(I/I_s)^{0.02} - 1} \quad t_i \text{ [s]}$$

Where  $t$  = Tripping time       $t_i$  = Time multiplier  
 $I$  = Fault current               $I_s$  = Setting value of current

Trip timing Accuracy : As per IEC-255-3 (2xI<sub>s</sub> to 20xI<sub>s</sub>)

DEFT / NINV 3.0 / 1.3 : ±5% OR ±30mSec (whichever is higher)

VINV / NINV 0.6 /EINV : ±7.5% OR ±40mSec (whichever is higher)

### DO Assignment

S.No	Parameter	Display	Setting Range
1	Phase over-current low set	OC	DO1/DO2/EXIT
2	Phase over-current hi-set	SC	DO1/DO2/EXIT
3	Earth over-current low set	E	DO1/DO2/EXIT
4	Earth over-current hi-set	EH	DO1/DO2/EXIT
5	Self supervision	SelfSup	DO1/DO2/EXIT
6	Circuit breaker failure protection	CBFP	DO1/DO2/EXIT

Note: DO 3 is common to all protections.

## DO Reset Mode

S.No.	Parameter	Display	Setting Range		Default Setting
			Min.	Max.	
1	Digital Output-1	DO 1	Auto	Manual	Auto
2	Digital Output-2	DO 2	Auto	Manual	Auto
3	Digital Output-3	DO 3	Auto	Manual	Auto

Note: DO 3 is common to all protections.

## Common Setting: (These are the settings common for all protections)

S.No.	Parameter	Display	Setting Range		Step Size	Default Setting
			Min.	Max.		
1.	Phase CT ratio	P-CTR	1	9999	1	1
2.	Earth CT ratio	E-CTR	1	9999	1	1
3.	Reset Delay	R_dly	0	20 Sec	0.1 Sec	0 Sec

## Auxiliary Supply

Rated Auxiliary voltage U <sub>H</sub>	18-60V DC (for L Model) or 85-280V AC / 100V-300V DC (for H model)
Power consumption	Quiescent approx. 3W    Operating <7W

## Measurement Accuracy

S.No	Quantity	Range	Frequency Range	Accuracy
1	Current	1 - 20 x I <sub>p</sub>	50 Hz	±2%

## 11) Technical Data

### Measuring Inputs

Rated Data	Rated current I <sub>p</sub> : 1A or 5A Rated frequency F <sub>n</sub> : 50 Hz
Drop out to Pickup Ratio	>96%
Power consumption in current circuit	At I <sub>p</sub> =1A    0.2 VA At I <sub>p</sub> =5A    0.4 VA
Thermal withstand capacity in current circuit	Dynamic current withstand (half wave): 250 x I <sub>p</sub> for 1 Sec : 100 x I <sub>p</sub> for 10 Sec : 30 x I <sub>p</sub> continuously : 4 x I <sub>p</sub>
Protection-Front Panel	IP-54
Weight	Approx. 1.0 Kg



## 12) Model Description Table

Function	IRIPRO-V3
CT Inputs	4
Over Current (50/51)	✓
Earth Fault (50N/51N)	✓
CBFP (50BF)	✓
Digital Output	3
Fault Record	5
Selection of 1/5A	Ordering information
Enclosure Type	Non Draw-out
Enclosure Size (WxHxD)	(136 x 68 x 134) mm

## 13) Connection Diagram IRIPro-V3-3I-EI

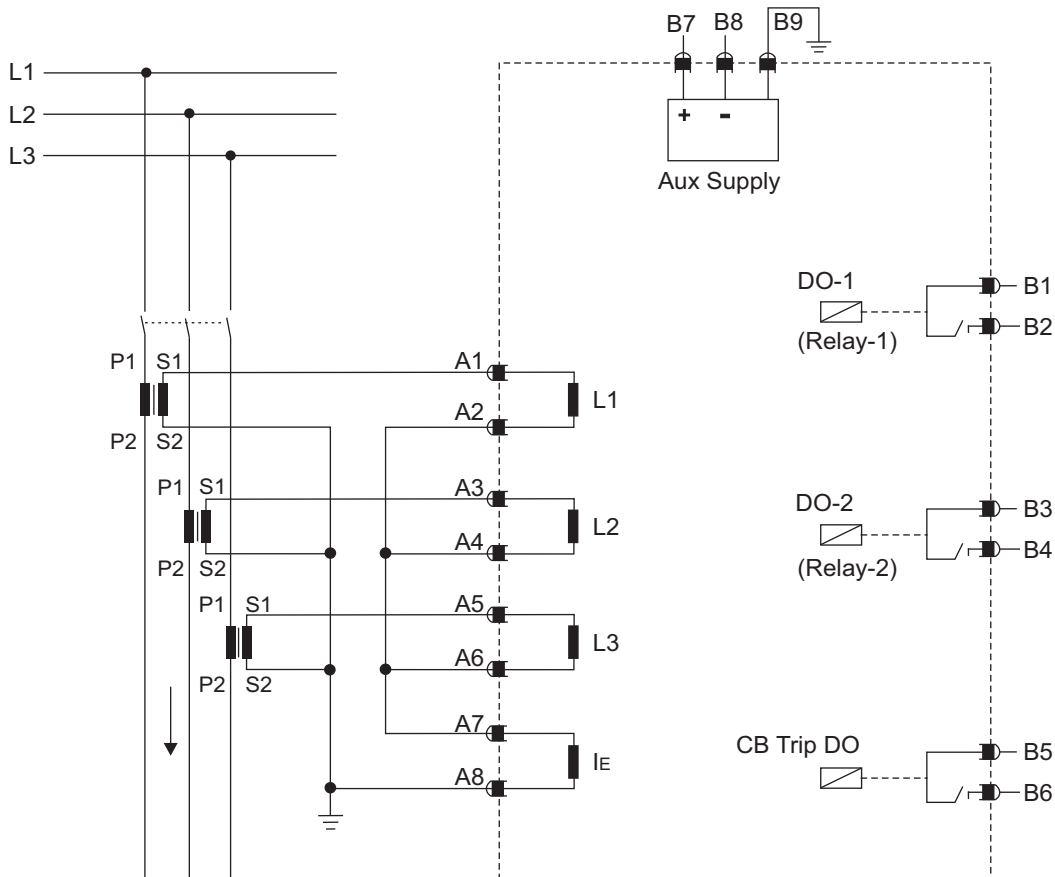

(Figure 5)

## Terminal Connection Details IRI-Pro-V3-EO

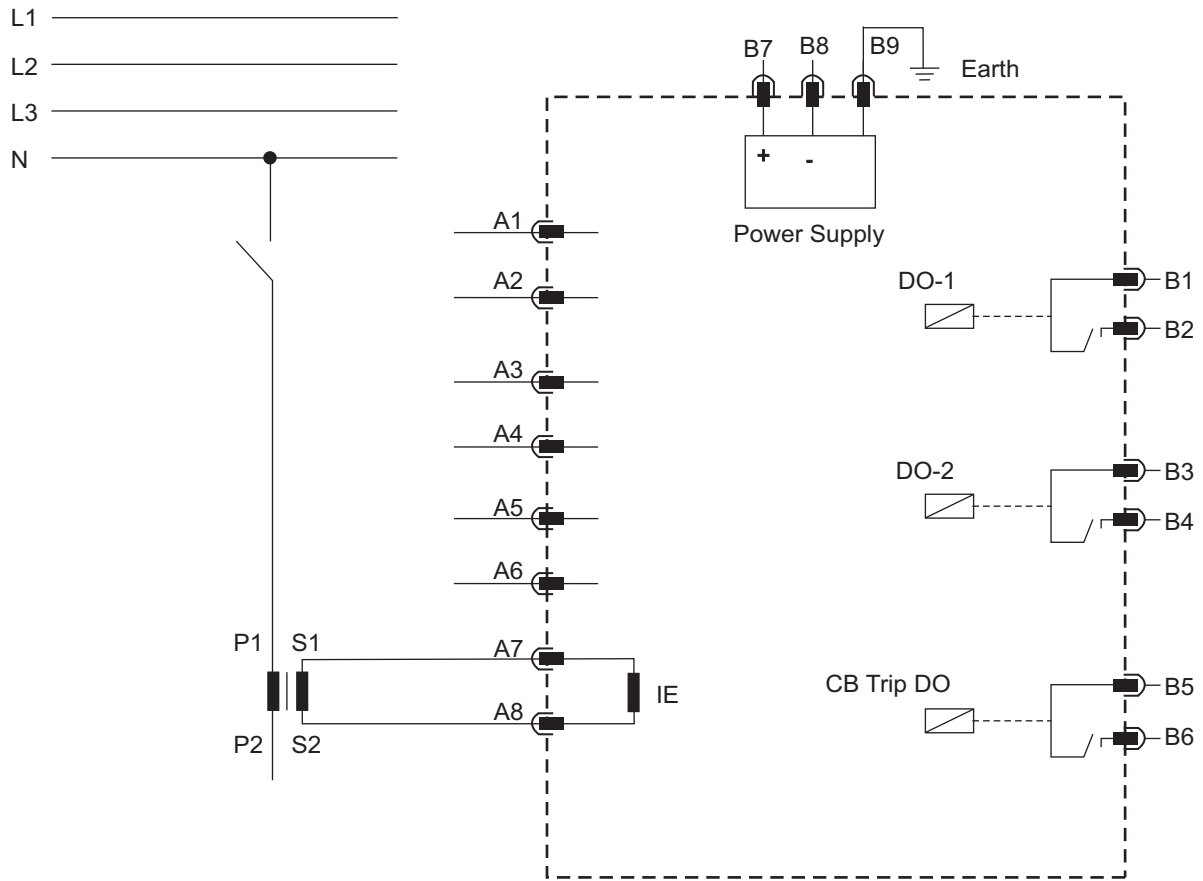

Back view of the Vertical Relay



## 14) Dimensional Details

Front View

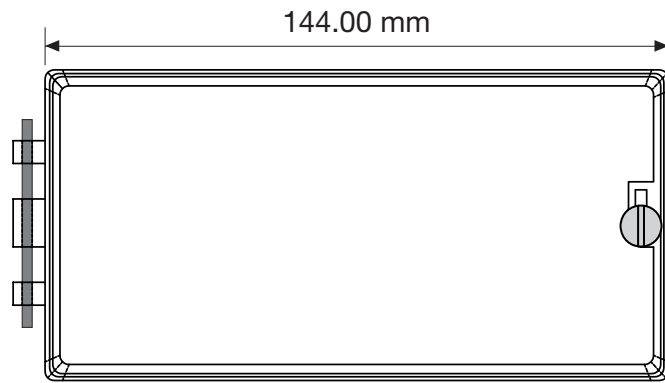

(Figure 6)

Side View

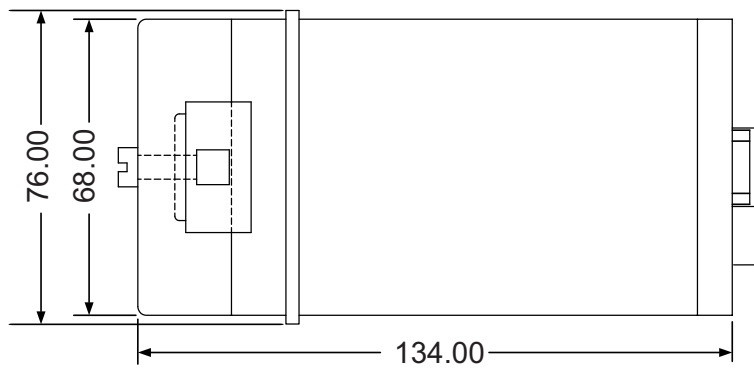

(Figure 7)

Top View

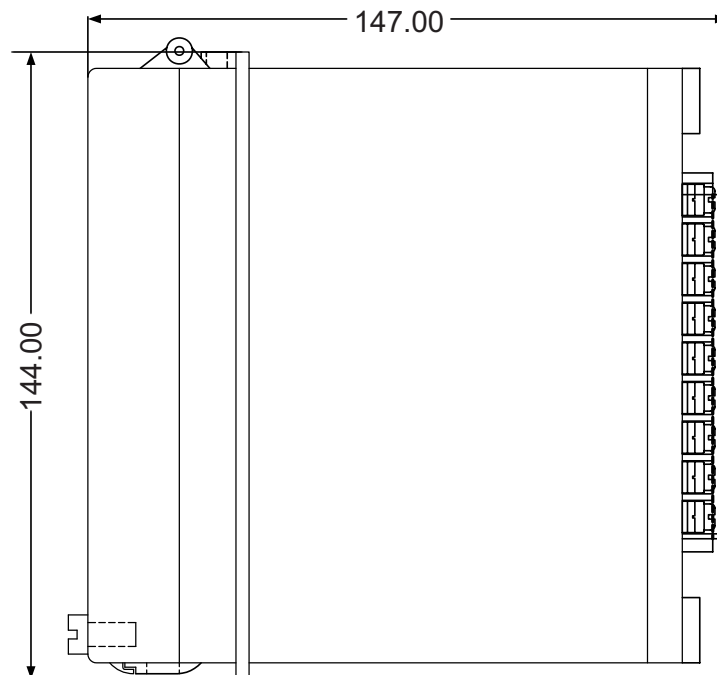

(Figure 8)

## 15) Panel Cut out Details

### Horizontal Relay

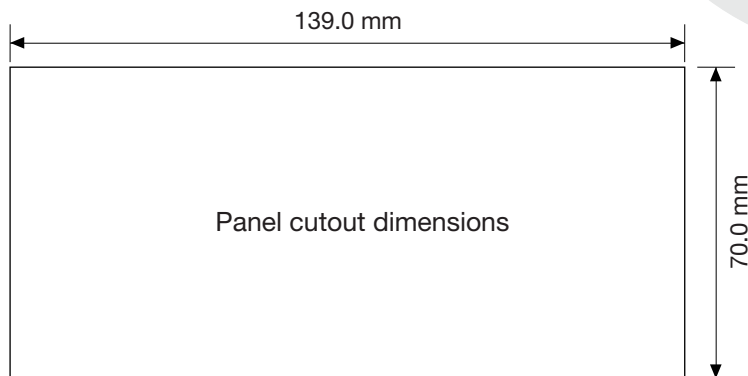

(Figure 9)

### Vertical Relay

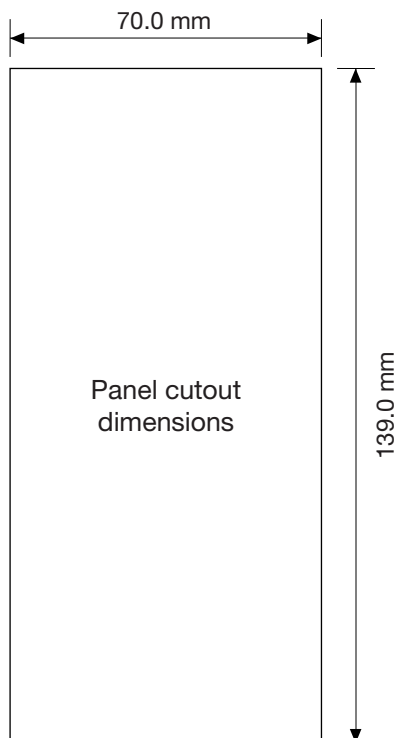

(Figure 10)

## 16) Ordering Information

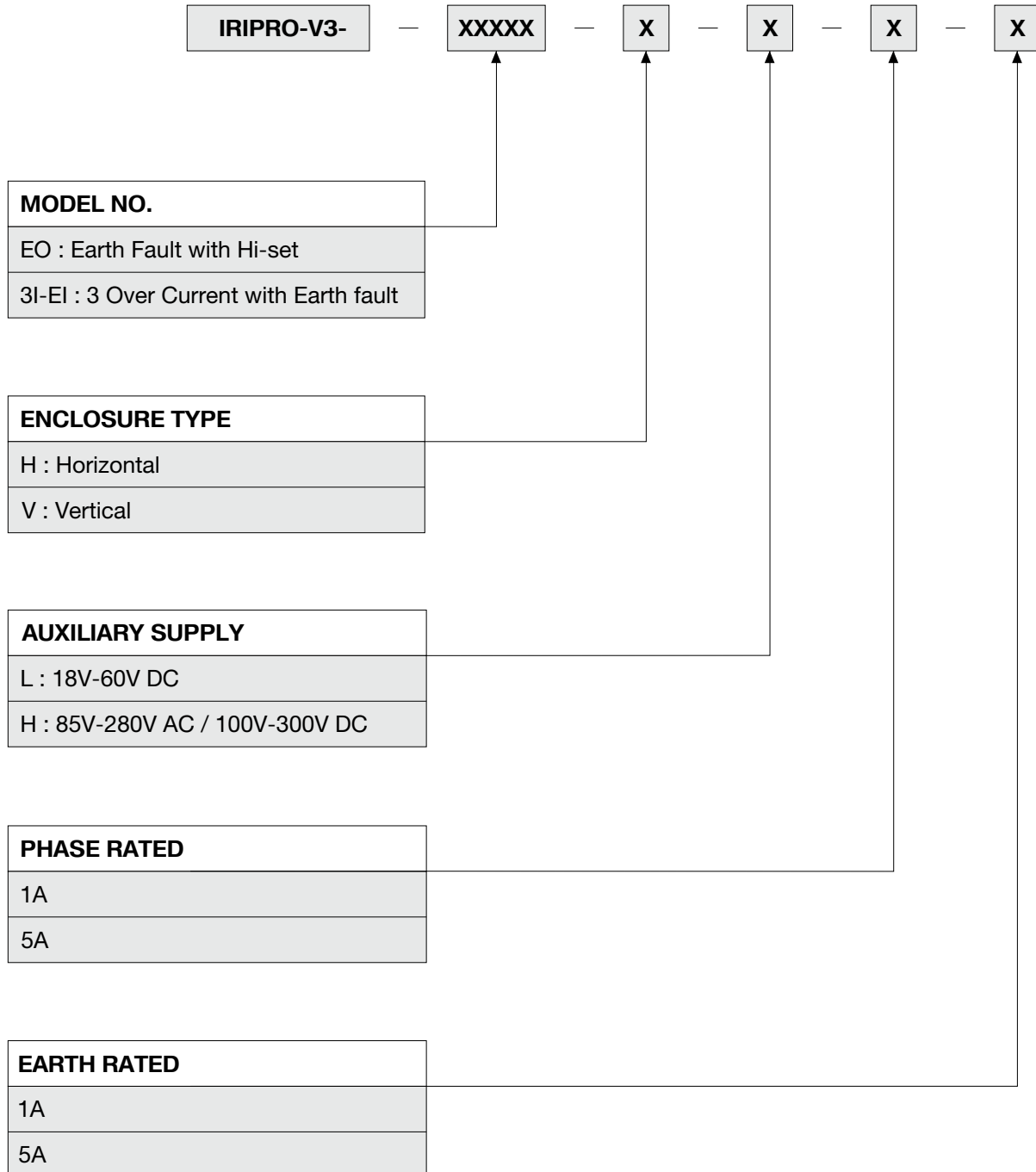

**Example:** IRIPRO-V3-EO-H-L-1-1

