

High-Tech Range

IRD1T2-WG Transformer Differential Protection Relay



C&S Electric Limited
(Protection & Measurement Devices)

Contents

- 1. Introduction**
- 2. Salient Features**
- 3. Design**
 - 3.1 Current Measuring Inputs
 - 3.2 Output Relays
 - 3.3 Front plate
 - 3.4 Fault Recording
- 4. Working Principle**
 - 4.1 Balancing of phases and current amplitudes
 - 4.2 Transformer Inrush
- 5. Setting recommendations**
- 6. Relay testing and commissioning**
 - 6.1 Power On
 - 6.2 Secondary injection test
 - 6.2.1 Trip level Id1
 - 6.2.2 Trip Level Id2
 - 6.2.3 Inrush blocking
- 7. Technical Data**
 - 7.1 Measuring Input
 - 7.2 General Data
 - 7.3 Output relay
 - 7.4 System Data
 - 7.5 Setting Ranges and steps
 - 7.6 Communication
 - 7.7 Tripping characteristics
 - 7.8 Setting Procedure
 - 7.9 Connection Diagram
 - 7.10 Dimensional details
- 8. Ordering Information**

1. Introduction

The Transformer Differential Numeric Relay type IRD1T2-WG is built around a powerful 32-bit Digital Signal Processor. It provides fast and selective tripping for two winding transformer. It quickly discriminates between faults that occur in the protected zone and those occurring outside this zone and thus provides selective and fast tripping. The faults within protected zone are short circuit between turns, windings and cables and earth faults inside transformer housing and protected zone.

IRD1T2-WG discriminates between above internal faults and the operational conditions like inrush, over-fluxing and faults external to protected zone using numerical algorithms.

2. Salient Features

- Numerical Relay
- Very low CT burden
- Built-in provision for CT ratio and phase angle corrections without external interposing CTs
- Dual slope characteristic
- Stabilization against inrush
- Prevention of nuisance tripping during transient CT Saturation
- Stabilization against transient over-fluxing
- High-set tripping threshold
- Universal auxiliary supply
- Galvanic isolation between independent inputs
- Wide setting range

3. Design

Refer to Fig. 3.1 for connection Diagram.

3.1. Current Measuring Inputs

The analogue secondary circuits of HV side are fed to the relay via terminals A3 to A8 and secondary currents of LV side via terminals B3 to B8.

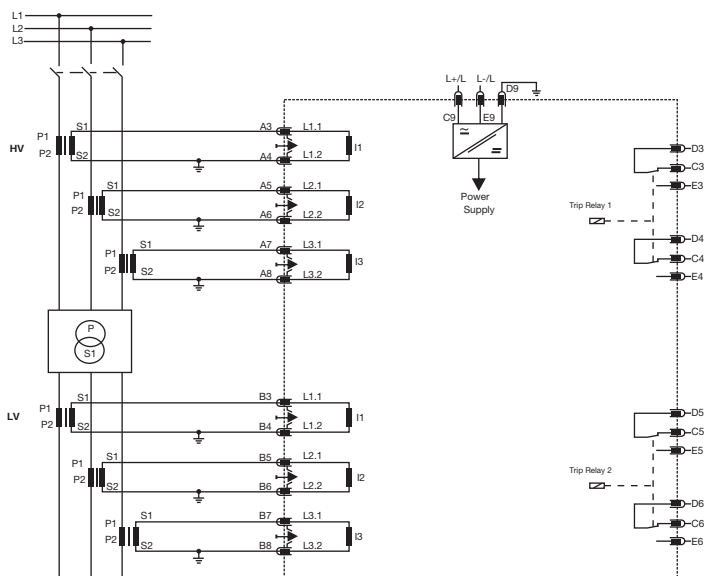

Fig. 3.1: Connection Diagram.

3.2 Output Relays

The IRD1T2-WG is provided with two tripping relay having two changeover contacts:

D3, C3, E3, D4, C4, E4, D5, C5, E5, D6, C6, E6

As it is shown, D3-C3, D4-C4 & D5-C5, D6-C6, are N/C contacts, whereas D3-E3, D4-E4 & D5-E5, D6-E6 are N/O ones. Contact positions will change on relay operation.

3.3 Front plate

At the front of the relay following operating and indicating elements are arranged:

- Five push switches for set values of normal tripping characteristics including a RESET push switch.
- Eight LEDs for indicating faults and readiness to operate.
- LCD display to display settings and running values etc.
- Running parameter's are $I_{d[fundamental]}$ for L1, L2, L3 phases.

The 'RESET' switch is provided for acknowledgement and reset of the 'TRIP' LED. Relay reset operation can be configurable in automatic reset or manual reset mode from MMI (man machine interface). In automatic reset mode relay will be reset after the current goes below the pick-up level. In manual mode relay will be reset by pressing reset button for 1 second.

The eight lamps on the front plate of IRD1T2-WG have following functions:

- Lamp 'ON' indicates that the relay is in service.
- Lamps L1, L2, L3 and 'TRIP' are fault indications.
- With lamp marked DI2
Stabilization against magnetizing inrush is indicated.
- Lamp N lights up for 2nd harmonic block tripping.
- Lamp COMM for communication indications.

3.4. Fault Recording

IRD1T2-WG records last three fault and saves following information in its EEPROM.

Reason of tripping	::	Hi-Set / Id >
Faulty phase	::	L1 / L2 / L3
Value at Fault	::	$I_{d[fun}]$, $I_{d[Res]}$, I_{d2H} , I_{d5H} for L1, L2, L3 phase in Amps

Fault1 is the latest fault.

4. Working Principle

Fig. 4.1 gives a general arrangement of differential protection.

The parameters are defined as below:

I_d = Differential (Tripping) Current

I_s = Stabilizing (Biasing) Current

The fundamental operating principle of transformer differential protection is comparison of Primary and Secondary winding currents on either side of the transformer.

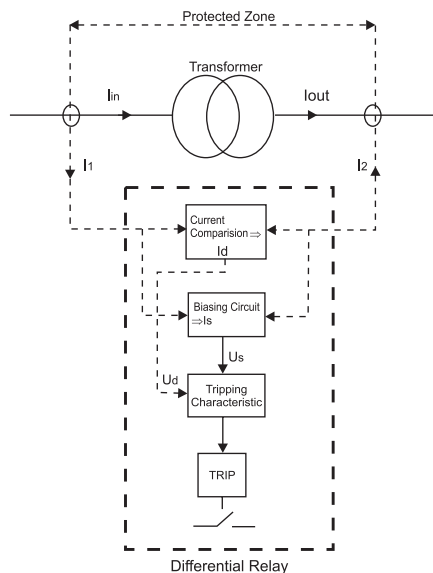

Fig. 4.1: General arrangement of differential Protection:

For an ideal transformer, having transformation ratio 1:1 and neglecting magnetizing current, the currents entering and leaving the transformer must be equal.

During normal operation or when a short circuit has occurred outside the protected zone [a through fault condition], the CT secondary currents in the differential circuit neutralize each other [$I_d=0$] and the relay will not operate.

In case of a fault within the zone, differential current I_d flows and operates the relay correctly.

Because of different problems mentioned below, however, in practice, measures for adaptation & stabilization have to be taken to ensure trouble-free operation of the transformer differential protection: *CT ratio errors on either side of the transformer and tap position of the tap changer*, Relay pickup setting is decided based on these factors.

Stability of the differential relay against external faults and CT saturation:

Variable bias techniques are used which restrain relay operation in these conditions. Magnetic inrush currents and over-flux conditions within the transformer core can cause mal-operation of the differential relay and call for advanced techniques to detect and restrain relay mal-operations in such conditions

4.1 Balancing of phases and current amplitudes

IRD1T2-WG Numeric relay provide the flexibility of fine adjustment of CT Ratio and Phase angle difference between Primary and Secondary sides of the transformer caused by Transformer ratio & Vector Groups. Vector group can be set as per actual configuration of transformer wiring at primary & secondary side. CT ratio correction is configurable on primary side in the range of 30% to 150% of I_n and same for the secondary side. External interposing CTs for ratio and phase angle corrections are not required for this numeric relay.

4.2 Transformer Inrush

When a transformer is first energized, a transient inrush current flows. This inrush current occurs only in the energized winding and has no equivalent on the other side of the transformer. The full amount of inrush current appears as differential current and would cause the differential relay to trip if there is no stabilization of the inrush phenomenon. Typically, the inrush current contains three components that distinguish it from true fault currents:

The DC component: The DC component is present at least in one phase of the inrush current, depending on the instant of energizing

The Second Harmonic: The second harmonic is present in all inrush currents due to unidirectional flux in the transformer core.

The Fifth Harmonic: The fifth harmonic is present when the transformer is subjected to a temporary over voltage. It indicates over flux conditions within the core.

The filter DSP algorithm detects not only CT saturation due to external fault, but also the magnetizing inrush current of the protected transformer.

The differential current I_d of each phase is analyzed separately. The signal of I_d passes through a filter algorithm detecting transient conditions due to DC component, the second harmonic and the fifth harmonic. Thus all three components are used for detecting an inrush current. The limits for blocking of the differential protection are:

DC component	:	$\geq 20\%$ of $I_{d(\text{fundamental})}$
2nd Harmonic	:	$\geq 20\%$ of $I_{d(\text{fundamental})}$
5th Harmonic	:	$\geq 20\%$ of $I_{d(\text{fundamental})}$

With this combined measurement of the three restraining components, IRD1T2 -WG achieves:

- Reliable inrush stabilization
- Fast tripping if the incoming transformer is defective
- Restraining feature against CT saturation

Whereas a complete blocking of the protection is only performed during the first energizing of the transformer, the harmonic content supervision restrains during normal

operation against phenomenon like CT saturation. This means that internal faults will be detected quickly, whereas external faults do not cause tripping.

The inrush blocking is stopped when:

The differential current shows an internal fault, according to the harmonic content OR The differential current exceeds Hi-Set setting.

5. Setting recommendations

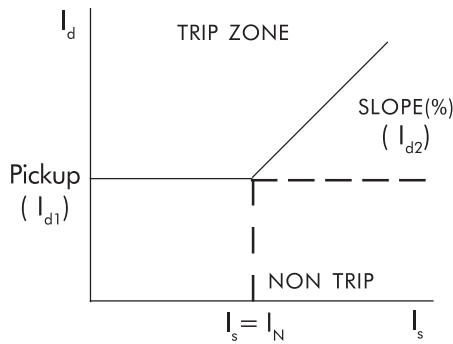

There are two parameters:

- [1] I_{d1} , expressed as fraction of I_N :Bias/pickup level
- [2] I_{d2} , expressed as fraction of I_s :Where I_{d2} is percentage restraining factor (% slope) & $I_s =$ Through current or restraining current or stabilising current

For $I_s < I_N$
 Tripping occurs at $I_d > I_{d1} \times I_N$

For $I_s > I_N$
 Tripping occurs at $I_d > I_{d2} \times I_s$

The tripping characteristic should be selected according to the known mismatch of the secondary currents fed to the relay plus a safety margin of 10 to 15%.This setting avoids mal-operation caused by normal load conditions.

Mismatch of the currents may be produced by:

- Ratio error and phase shifting of the CTs e.g. for Protection CTs of accuracy class 10P20 rating, the ratio error at normal current is 3%. At 20 times the nominal current, the ratio error reaches 10%.
- On-Load-Tap-Changer (OLTC). The automatic OLTC may vary the ratio of the protected transformer as much as $\pm 10\%$. This causes a current mismatch of the same amount.

Note: The ratio mismatch caused by the transformer ratio should be compensated by the CT ratio correction settings of primary/secondary.

Setting for CT ratio correction factor :

The CT ratio matching correction settings **Pri Corr/Sec Corr** can be calculated as follows.

For transformer capacity, take the maximum one from the rated capacity of the two windings.

Calculation steps	(HV)	(LV)
(1) Transformer capacity :10 MVA		
(2) Voltage (kV)	33	11
(3) Rated line current(A)	175	525
(4) CT ratio	200/1	800/1
(5) Secondary rated line current (A)	0.87	0.65
(6) CT Secondary rating of relay (A)	1	1
Setting Pri Corr/Sec Corr	PriCorr=0.87	Sec Corr=0.65

$$\text{CT correction factor} = \frac{\text{Rated line current}}{\text{CT ratio} \times \text{CT Secondary rating of relay}}$$

Note: The CT Ratio correction factor calculation is irrespective of selected vector phasor group.

Setting of HBLOCK

HBLOCK is set to detect the second/5th harmonic content in the inrush current during transformer Energization or transient over-excitation conditions and blocks IRD1T2 to prevent incorrect operation due to the inrush current. A setting of 20% is suggested if there is no data on the minimum second/5th harmonic content.

Note : Put this setting in DISABLE mode unless required

Working of Corse Setting

If Corse Setting is enabled & harmonics are present, relay will bypass the user settings & will shift to predefined setting of $I_{d1} = I_{d2} = 60\%$ (fix) & will trip the breaker if differential is above these fixed settings. But if harmonics are not present then relay will work as per its set pickup values. if Corse Setting is disabled & harmonics are present, relay will not pickup on any level.

6. Relay testing and commissioning

Correct connections of primary and secondary side of the CTs as well as the correct connection and adjustment of the internal matching CTs are the conditions for a perfect service of the differential relay.

The transformer differential relay will be pre-adjusted at factory according to the order form. When taking the relay into service the commissioning checks explained below should be followed.

The test instructions following below help to verify the protection relay performance before or during commissioning of the protection system. To avoid relay damage and to ensure a correct relay operation, please ensure that:

- The auxiliary power supply rating corresponds to the auxiliary voltage on site.
- The rated current corresponds to the plant data on site.

The current transformer circuits are connected to the relay correctly. It is very important to ensure that the polarity of the current circuit is correct. Please pay special attention also to the primary connections of the CTs. In most cases a wrong connection of the C.T.s is the reason for mal-

operation of the differential protection. If all connections are correct and the internal measuring value still shows deviations from the expected values then check the transformer vector group.

For crosschecking CT connections, first of all make the connection as per connection diagram 7.9 and then inject Iz AMP current in all CTs & check as per following sequence

- A3-A4 (L1 primary) : Iz Amp
- B3-B4 (L1 secondary) : Iz Amp
- A5-A6 (L2 primary) : Iz Amp
- B5-B6 (L2 secondary) : Iz Amp
- A7-A8 (L3 primary) : Iz Amp
- B7-B8 (L3 secondary) : Iz Amp

S.No	LCD Display Status	CT Connection Status
a)	I _{L1d} = 0 and /or I _{L2d} = 0 and /or I _{L3d} = 0	Correct CT Connection
b)	I _{L1d} = 2 x Iz Amp and / or I _{L2d} = 2 x Iz Amp and / or I _{L3d} = 2 x Iz Amp	Wrong CT Polarity
c)	I _{L1d} = 1.72x Iz Amp and / or I _{L2d} = 1.72x Iz Amp and / or I _{L3d} = 1.72x Iz Amp	Wrong Phase CT (eg one current from L1 phase the other one from L2 phase)

Note : Above mentioned values with in claimed tolerance band

6.1 Power on

Prior to switching-on the auxiliary power supply, be sure that the auxiliary supply voltage corresponds with the rated data on Name Plate. When the auxiliary supply is switched on please observe that the LED "ON" starts flashing. A flashing LED also indicates that CPU is functioning normally which act as watch dog check of relay.

6.2 Secondary injection test

Test equipment:

- One adjustable current source up to two times nominal current of the relay
- Ampere meter with class 1.0 accuracy.
- Auxiliary supply source corresponding to the rated supply range.
- Power diode (10A)
- Switching device
- Test leads and tools

6.2.1 Trip level Id1

Inject a current into each current input according to the test circuit below and check the current value at which a trip occurs. The tripping values should correspond to the setting of Id₁ if I_s < I_N for example if I_{pri} = 1A & I_{sec} = 0.7A & Id₁ = 20% then tripping occurs because Id > Id₁ X I_N.

6.2.2 Trip Level Id2:

Refer to Fig. 4.1 for sign convention of currents.

Observe that pick up happens when Id exceeds Id₂ x I_s when I_s > I_N.

$$I_s/I_N = [I_{pri} - I_{sec}]/2 \text{ and } I_d/I_N = [I_{pri} + I_{sec}]$$

Id₂ is applicable when I_s > I_N.

Thus tripping results when

$$[I_{pri} + I_{sec}] > Id_2 \times [I_{pri} - I_{sec}]/2 \text{ for } I_s > I_N.$$

On simplification it yields the following relationship:

$$I_{pri} > -I_{sec} [2 + Id_2] / [2 - Id_2] \text{ for } I_s > I_N$$

Based on above relationship some sample values of Id₂ and I_s are chosen. Based on these choices I_{pri} and I_{sec} are calculated and tabulated in Table 6.1.

Table : 6.1 Sample values for testing Id₂

Id2(slope)	Is	I _{sec}	I _{pri}	Id
0.300	1.20	1.02	1.38	0.36
0.400	1.20	0.96	1.44	0.48
0.300	2.00	1.70	2.30	0.60
0.400	2.00	1.60	2.40	0.80
0.425	3.00	2.36	3.64	1.28
0.425	1.05	0.83	1.27	0.44

Tripping shall happen when actual Id exceeds the value in table.

$$Id = \sqrt{I_{d[\text{fundamental}]}^2 + I_{d2nd\text{harmonic}}^2 + I_{d5th\text{harmonic}}^2}$$

6.2.3 Inrush blocking

The inrush blocking may be tested with a sample test circuit, shown in Fig. 6.2.

Adjust the input current to approximately 1.5 times the nominal current.

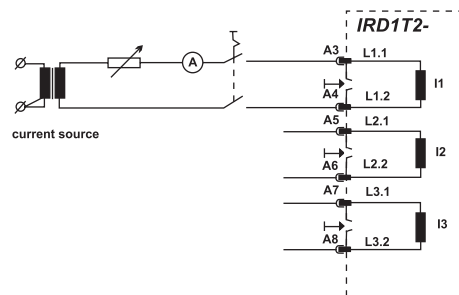

Fig. 6.2: Inrush blocking

7.1 Measuring Input

Rated data	Rated current I _N Rated frequency F _N	1A or 5A 50Hz
Power consumption in current circuit	At I _N = 1A At I _N = 5A	0.2 VA 0.1 VA
Thermal withstand capability in current circuit	dynamic current withstand (half-wave) for 1 s for 10 s continuously	250 x I _N 100 x I _N 30 x I _N 4 x I _N

Rated auxiliary voltage U_H	Working range Working range	24 -270VAC /24 -360 VDC
DC Power consumption	Standby approx 3W Standby approx 3W	Operating appx 6W Operating appx 6W

7.2 General Data (At Rated current and Rated Frequency)

Dropout ratio	> 96 %
Returning time	50 ms
Hi-Set Trip time	<= 20 ms (Tolerance + 5ms)
Hi-Set Pickup	+/- 5%
Differential Current Resolution	1% x I_n
Differential Current Accuracy	+/- 15 mA upto 40% of I_n , onwards +/-2%
Low-Set trip time	<=40ms (Tolerance \pm 5ms)
Measurement Range	15% to 20 x I_n

7.3 Output Relay

Maximum breaking capacity	250 V AC / 1500 VA / continuous current 6 A			
For DC-voltage		Ohmic	L/R = 40 ms	L/R = 70ms
	24 V DC	6 A / 144 W	4.2 A / 100 W	2.5 A / 60 W
Max. rated making current	64 A (VDE 0435 / 0972 and IEC 65 / VDE 0860 / 8.86)			
Mechanical life span	30 x 10 ⁶ operating cycles			
Electrical life span	2 x 10 ⁵ operatingcycles at 220 V AC / 6A			
Contact material	Silver cadmium oxide (AgCdO)			

7.4 System Data

Design Standard	IEC60255-13
Specified ambient service storage temperature range	-40 deg C to + 85 deg C
Operating Temperature range	-20 deg C to 70 deg C
Environment Protection	IEC60068-2-3, relative humidity 95% at 40 deg C
Insulation Test Voltage, inputs and outputs between themselves and to the relay frames as pr IEC 60255-5	2.5 KV, 50Hz, 1 min
Impulse test voltage, inputs and outputs between themselves and to relay frame as per IEC 60255-5	5KV; 1.2 / 50 μ S; 0.5 J
High Frequency Interference test as per IEC60255-22-1	2.5KV / 1 MHz
Electrostatic Discharge test as per IEC 60255-22-2	8KV
Radiated electromagnetic field immunity test IEC60255-22-3	Electric field strength 10 /m
Electrical fast transient (Burst) test as per IEC60255-22-4	4 KV / 2.5 KHz, 15ms
Radio interference suppression test	EN55011
Shock response test	IEC60255-21-2
Vibration response test	IEC60255-21-1
Weight	Approx. 1.5 Kg
Mounting Position	any

7.5 Setting Ranges and Steps

Parameter	Display	Setting range	Step	Tolerances
Slope I_{d1}	I_{d1}	5.00% – 45% x I_N	1%	± 5 % from set value
Slope I_{d2}	I_{d2}	5.00% – 45% x I_s	1%	± 5 % from set value
Primary / Secondary CT Correction Factor	PriCorr/ Sec Corr	0.3 – 1.5 x I_N	0.01	± 3 % from set value
Vector Group setting	VGSET	YD1,YD3,YD5,YD7,YD9, YD11, DY1,DY3,DY5,DY7,DY9 DY11, YY0,DD0, YY2, DD2, YY4, DD4, YY6, DD6, YY8, DD8, YY10, DD10	—	—
5 th Harmonic/2 nd Harmonic Pickup Blocking	HBLOCK	20% to 50%	5%	± 5 % from set value
High-set Pickup	Hi-Set	500 – 1500% x I_n	100%	± 5 % from set value

7.6 Communication

Front Port (RS 232)

Front Port Protocol	::	CSE Open protocol with "CSE LIVELINK" on null modem cable
---------------------	----	---

Rear Port (RS 485)

Rear port protocol	::	MODBUS RTU
Baud rate	::	19200 baud
Parity	::	None
Stop Bit	::	1 bit
Data Bit	::	8 bit data
Remote Address	::	1-32(Editable)

7.7 Tripping Characteristics

S. No.	Parameter	Specification	Status
1.	Relationship between differential and stabilizing current.	<p>Tripping Pickup Characteristics</p>	
2.	Trip time characteristic	<p>Tripping Time Characteristics</p>	

7.8 Setting Procedure Menu Frames

MENU	DISPLAY	DISCRIPTION
Menu 1 Default Page (Running Parameters)	L1d, L2d, L3d <TRIP> L1L2L3 / BLOCK	Differential fundamental Current TRIP Status
Menu 2 (Pressing Reset Key)	#STATUS# <EDIT> <FAULT1> <FAULT2> <FAULT3> <VER> <PSWD> BACK	EDIT MENU LAST FAULT FAULT BEFORE FAULT1 FAULT BEFORE FAULT2 RELAY VERSION Password
Menu 3 (Pressing Reset Key on EDIT selection)	#EDIT# <Id1> < Id2> <VGSET> <Hi-set> <CTcorr> <HBlock> <Coarse> <FCTSET> <SL.ADD> <Reset > BACK	1st Bias Setting 2nd Bias Setting Vector group Setting Hi-set setting CT correction Setting Harmonic setting Coarse setting Factory setting Slave address Relay Reset Type
Menu 4 (Pressing ResetKey on Id1 selection)	#Id1# XX.XX BACK	$Id \geq Id1 \times IN$
Menu 5 (Pressing Reset Key on Id2 selection)	#Id2# XX.XX BACK	$Id \geq Id2 \times IS$
Menu 6 (Pressing Reset Key on VGSET selection)	#VGSET# XXX BACK	For phase angle correction
Menu 7 (Pressing Reset Key on Hi-Set selection)	#Hi-set# XX x In	For Hi-Set setting
Menu 8 (Pressing Reset Key on CTcorr selection)	Enter PWD #CT corr# <Prim> <Sec> BACK	For primary and secondary CT ratio correction
Menu 9 (Pressing Reset Key on Prim selection)	#PriCorr# X.XX BACK	For primary side of CT ratio correction
Menu 10 (Pressing Reset Key on Sec selection)	#Sec Corr # X.XX BACK	For secondary side of CT ratio correction
Menu 11 (Pressing Reset Key on H Block selection)	#BLOCKH# <2nd HL> <5th HL> <BlkTyp> BACK	2 nd harmonic limit 5 th harmonic limit harmonic blocking type

MENU	DISPLAY	DISCRIPTION
Menu 12 (Pressing Reset Key on 2nd HL selection)	#2nd H# X.XX %If BACK	2 nd harmonic Blocking limit
Menu 13 (Pressing Reset Key on 5th HL selection)	#5th H# X.XX % If BACK	5 th harmonic Blocking limit
Menu 14 (Pressing Reset Key on BlkTyp selection)	# H-BLK # 3 PHASE / 1-PHASE BACK	harmonic Blocking by 3-phase /1-phase
Menu 15 (Pressing Reset Key on Coarse selection)	# Coarse # Disable / Enable BACK	Coarse Disable / Enable setting
Menu 15 (Pressing Reset Key on SL.ADD selection)	# SL-ADD # S.A: XX BACK	Slave address setting
Menu 16 (Pressing Reset Key on Reset selection)	# RESET # AUTO / MANUAL BACK	Relay Reset Type
Menu 17 (Pressing Reset Key on FAULT1,2,3 selection	# F-MENU # <TRIP> HI-Set/Id> [F] L1d XX.XXA [F] L2d XX.XXA [F] L3d XX.XXA [F] L1Res XX.XXA [F] L2Res XX.XXA [F] L3Res XX.XXA [F] L1d2H XX.XXA [F] L2d2H XX.XXA [F] L3d2H XX.XXA [F] L1d5H XX.XXA [F] L2d5H XX.XXA [F] L3d5H XX.XXA BACK	Fault Occurred
Menu 18 (Pressing Reset Key on VER selection	# VER # VER:VX.XX DN: XX/XX BACK	Released version of relay
Menu 19 (Pressing Reset Key on CHG PSWD selection)	?PSWD? New PSWD Re- PSWD SUCCESS PSWD CHG	
Menu 20	Save? YES NO	
Menu 21	? PSWD ? SAVING ...	
Menu 22	PSWD ! INVALID	

Basic Key Functions

KEY	FUNCTION
RESET	Reset annunciation/Enter Key confirm selection of item in the menu & save value
▲	Up scroll for the menu
+	Increment selected parameter
-	Decrement selected parameter
▼	Down scroll for the menu

NOTE::All keys can be used in selecting / specifying password Pressing Reset key for 1 sec, cursor will go back to the previous page.

7.9 Connection Diagram

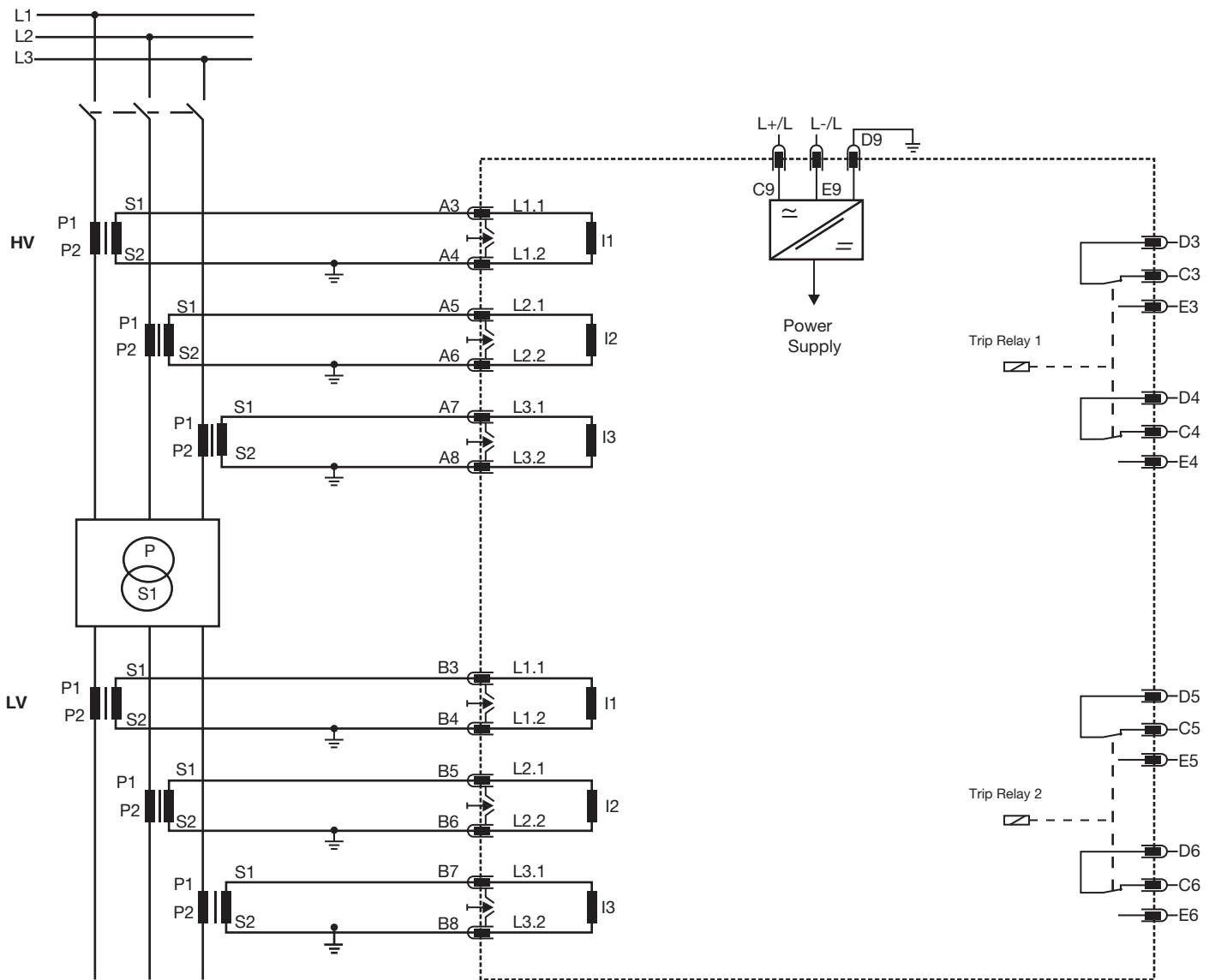

7.10 Dimensional details

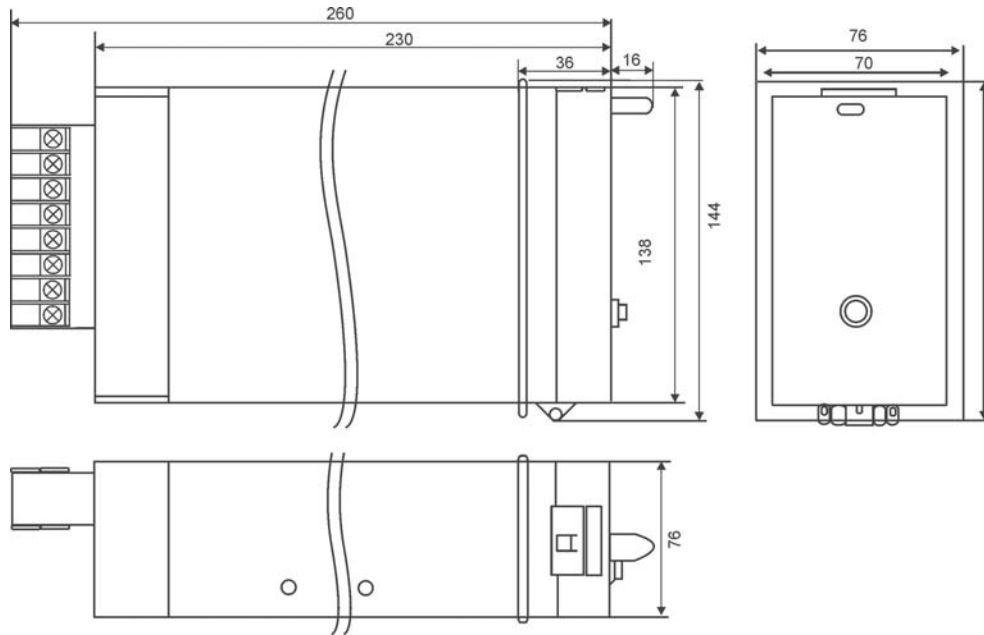

Please observe:

A distance of 50 mm is necessary when the units are mounted one below the other for the housing bonnet to be easily opened. The front cover can be opened downwards.

8.0 Ordering Information

MODEL NO.:

IRD1

-

XX

-

WG

-

1A

Transformer Differential Relay : T2

Generator Differential Relay : G2

Generator Differential is available in fixed YY0 Vector group / without any harmonic Blockage.
Technical data subject to change without notice!

For further information, please contact:

C&S Electric Ltd. (Protection & Measurement Devices)

C-60, Wing-A, Phase-II, Noida -201 305, District Gautam Budh Nagar (U.P) INDIA

Phone : +91-120-305 7700 / 01, Fax : +91-120-305 7704

E-mail: marketing.cspc@cselectric.co.in

Branch office

Issue Date : 21.10.10

Rev. No : 02

Rev. Date : 17.07.15

Branch	Phone	Fax	E-mail
Ahmedabad:	+91 79 30074534/35/36	+91 79 30074519	cspc.ahmedabad@cselectric.co.in
Bangalore:	+91 80 3057 0372/73, 3057 0347	+91 2558 4839	cspc.bangalore@cselectric.co.in
Bhubaneswar:	+91 674 2507265	+91 674 2507265	cspc.bhubaneswar@cselectric.co.in
Chennai:	+91 44 3918 0531-35	+91 44 39180514	cspc.chennai@cselectric.co.in
Cochin:	+91 0484 3071717	+91 0484 3071716	cspc.cochin@cselectric.co.in
Delhi:	+91 11 30838822-25	+91 11 30838826	cspc.delhi@cselectric.co.in
Hyderabad:	+91 40 3918 2496/97	+91 40 3910 3631	cspc.hyderabad@cselectric.co.in
Kolkata:	+91 33 22275850/51	+91 33 2227 5849	cspc.kolkata@cselectric.co.in
Mumbai:	+91 22 30487146/47/48	+91 22 2412 6631	cspc.mumbai@cselectric.co.in
Pune:	+91 20 30283244/45	+91 20 30283244	cspc.pune@cselectric.co.in

We touch your electricity everyday!