

We touch your **electricity** everyday!

CSNEX-I 450

● Intelligent Measuring & Protection Device



Catalog



PMD Division

CONTENTS

S.No.	Description
1.	Introduction
2.	Features
3.	Application
4.	Hardware
5.	Protection Features
6.	Functional Diagram
7.	Fault Record
8.	Event Record
9.	Disturbance Record
10.	Programmable Scheme Logic
11.	Human Machine Interface
12.	Communication
	12.1 Rear Communication
	12.2 Front Communication
13.	Setting Ranges
14.	Technical Data
15.	Specification Table of I-450
16.	Standards
17.	Recommended Terminal Lugs Specification
18.	Connection Diagram (8 DI & 8 DO)
19.	Terminal Description (8 DI & 8 DO)
20.	Dimensional Details
21.	Panel Mounting Details
22.	Ordering Information



1) Introduction

CSENEXT Series offers a compact Multi-functional Over-current protection solution for Feeder, Generator, Motor & Transformer segment.

CSENEXT-I Family of protective relays are numeric relays that provides multi protection and monitoring with reliable and fast protection solution in a single unit.

In this family of CSENEXT series, the CSENEXT-I 450 is an advanced feeder protection solution which has fast, sensitive and secure protection for feeder internal & external faults.

CSENEXT-I offers different model based features to cover the wide range of user.

2) Features

- ❖ 1A & 5A rated CT input (programmable)
- ❖ Draw out with self CT shorting
- ❖ DI/DO programmable matrix
- ❖ Protection blocking through DI
- ❖ Three phase time over-current protection
- ❖ Three phase instantaneous protection
- ❖ Protection against Cold Load
- ❖ Earth time over-current and earth instantaneous over current
- ❖ Circuit breaker failure detection
- ❖ Zero Phase Sequence / Positive Phase Sequence / Negative Phase Sequence
- ❖ Trip Circuit supervision
- ❖ CT Supervision function
- ❖ Self supervision function (Watchdog can be configured on output)
- ❖ Thermal Over load
- ❖ Auto Re-closing function
- ❖ Two sets of setting groups
- ❖ Programmable Scheme Logic
- ❖ Disturbance recording
- ❖ Two level password protection
- ❖ Fault recorder
- ❖ Event recorder
- ❖ Communication (Local & Remote)

3) Application

The CSENEXT-I relays have been designed for controlling, protecting and monitoring industrial, utility distribution networks and substations. They can also be used as part of a protection scheme for feeders, transformers and generators.

4) Hardware

- ❖ Measures true RMS with DFT filter
- ❖ 4 Current analog inputs for phase & earth fault current
- ❖ Max. 8 Digital Inputs
- ❖ Max. 8 Digital Outputs with WDG
- ❖ 16 x 2 Alpha-numeric LCD
- ❖ RS-485 & USB communication
- ❖ 1A & 5A site selectable
- ❖ 16 LEDs for Pickup & fault annunciation
- ❖ CT Terminal with Self shorting

5) Protection Features

- ❖ Three phase time over current protection (51)
- ❖ Three phase instantaneous protection (50)
- ❖ Earth time over-current (51N)
- ❖ Earth instantaneous over-current (50N)
- ❖ Thermal over load (49)
- ❖ Circuit breaker failure protection (50BF)
- ❖ Harmonic Restrain (50H)
- ❖ Trip Circuit Supervision (74TC)
- ❖ Cold Load (62 CLD)
- ❖ Auto Re-closer (79)

6) Functional Diagram

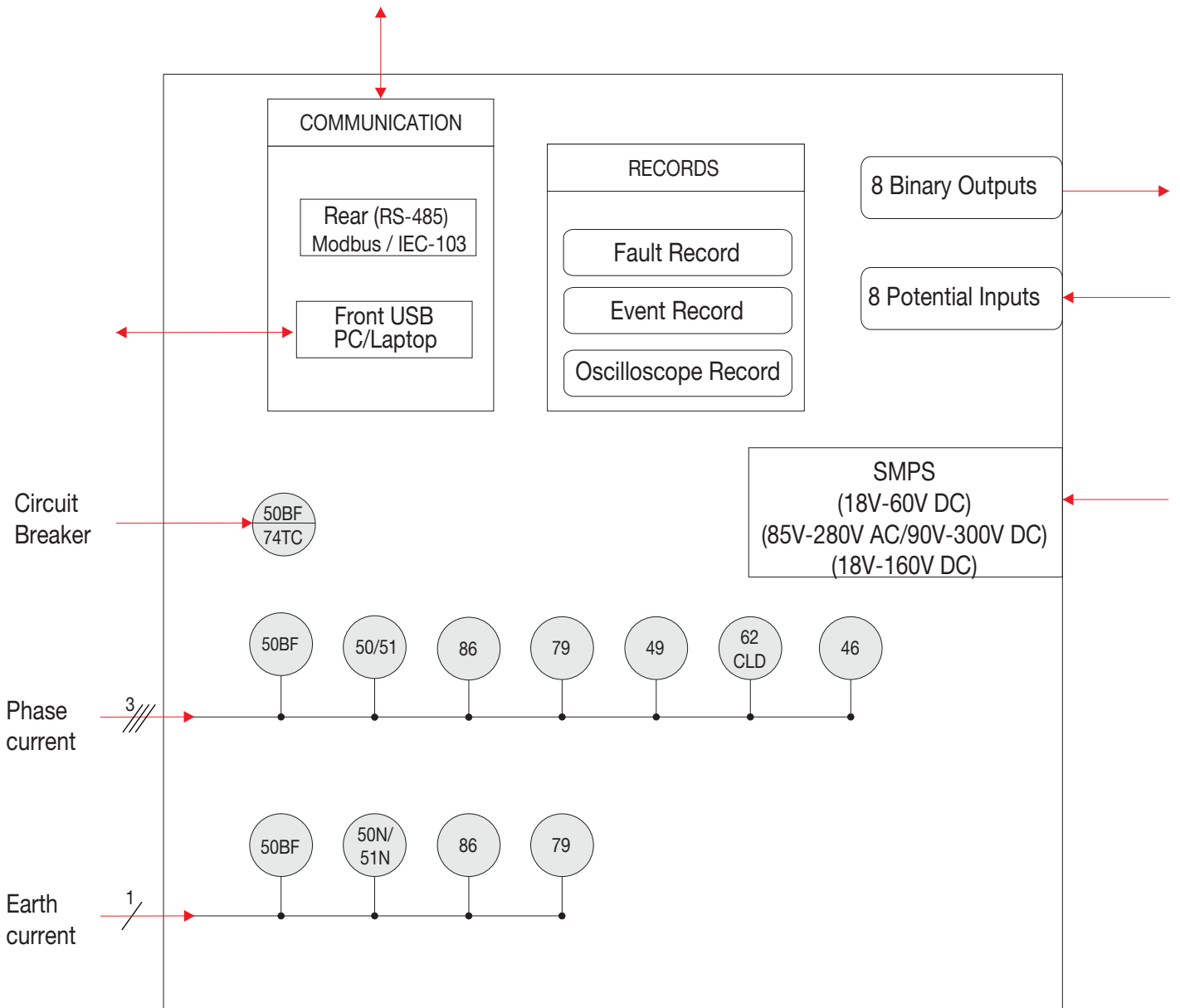

(Figure 1)

Protection Functions

Three Phase Over-current Protection (50/51)

The independent two stages are available for phase fault protection. For $I >$ the user may independently select definite time delay or inverse time delay with different type of curves. The second Hi-Set stage can be configured with definite time only.

Earth Fault Protection (50N/51N)

The independent two stages are available for earth fault protection. For first stage ($I_e >$) the user can select definite time delay or inverse time delay with different type of curves. The second Hi-Set stage can be configured with definite time only.

Relay Latching (86)

Relay can be configured to Latch /Unlatch depending on configuration. (Latching is possible in presence of Auxiliary supply voltage only)

Harmonic Blocking

Harmonic setting is by default 20% of injected current. Phase/Earth Harmonics can be Blocked/Unblocked & time setting can also be edited through MMI. If the Pickup current has %harmonics above 20%, the protection will be blocked for the harmonics blocking time. Tripping occurs according to the higher time setting i.e. if the harmonics time setting is greater it will trip according to the harmonics time setting otherwise according to the fault time setting.

Negative Phase Protection (46)

It contains the inverse and definite time characteristics. This protection works exactly in the same way as phase over current but I_2 is a combination of all three currents. Its amplitude also depends on the phase angle.

$$3|I_2| = |I_a + a^2 I_b + a I_c|$$

Where $a = 1 \angle 120^\circ$

Circuit Breaker Failure Protection (50 BF)

The CB Failure Protection is based on supervision of phase and earth currents after tripping events. The test criterion is whether all phase currents have dropped to less than 5% of I_n within t_{CBFP} . If one or more of the phase currents have not dropped to specified current within this time, CB failure is detected and the assigned output relay is activated.

Auto Re-closer (79)

As 80% of faults in overhead lines are transient, the use of the auto re-closer is very advantageous. Automatic auto-recloser allows a substation to operate unattended. The number of visits on site to manually re-close a circuit breaker after a fault, can then be substantially reduced. This feature gives an important advantage for substations supervised remotely.

Typically this auto re-close (AR) sequence of Instantaneous Trip(s) and Re-close Delays (Dead times) followed by Delayed Trip(s) provide the automatic optimum method of clearing all types of faults i.e. both Transient and Permanent, as quickly as possible and helps in improving the up time of the network in service.

DI Inputs:

AR Blocking - To block the auto re-closer through remote DI
 CB Close DI - To get the circuit breaker status
 CB Ready - To get the CB ready or to give the closing command

Configurable Outputs:

79 AR Close CB
 79 Lockout

AR-Blocked:

Unit changes immediately to "AR-blocked" status when an external AR Blocking DI is applied or internal EXIT is chosen for AR cycle in MMI. No Auto re-closing is possible in "AR-blocked" status.

Activating of AR:

Prior to every AR it is possible to select which kind of tripping (I_1 or $I_{2>>}$, I_e etc.) will lead to automatic re-closing. This can be separately fixed for each protection.

Dead time (td):

Starts with the off signal of the circuit breaker. No closing command to the circuit breaker is given till expiry of the set dead time.

User programmable dead times are available for each protection trip operation. The dead time is initiated when the trip output contact resets, the pickup is reset and the CB is open.

The CB close output relay is energized after the dead time has elapsed if CB ready input is present.

The dead time (dead time td_1 , dead time td_2 , dead time td_3 , dead time td_4) starts when the feedback on 'CB CLOSE DI' is not available.

NOTE: Trip Test is available in HMI to check all LEDs and Digital Output (Relay)

Reclaim Time (tr)

This is the time during which after switching on or after AR a subsequent re-closing is prevented. If the number of the set shots is reached, the relay is locked for this time after the last re-closing attempt. If CB Ready DI is not available relay will not generate closing command.

If the circuit breaker does not trip again, the auto re-close cycle resets to original STATE-1 at the end of the reclaim time.
If the protection operates during the reclaim time of the relay:

- ❖ either advances to the next AR cycle that is expected in next auto re-close state or
- ❖ if all the programmed re-closer attempts have been accomplished, it locks out.

The reclaim time is started with the automatic closing command.

Once a CB has re-closed and remained closed for a specified time period (the reclaim time), the AR sequence is reinitialized and a successful close output issued. A single common reclaim time is used (Reclaim Timer). when an auto re-close sequence does not result in a successful re-closure the relays goes to the lock out state.

Starting Condition for Auto Re-closer

- 1) AR should be enabled by manual setting.
- 2) AR blocked DI is not available
- 3) Respective protection AR cycle should not in exit condition.

Lock out State

Lockout state of the breaker means no further attempts to AR in these conditions

- 1) Lockout occurs when all auto re-closure attempts are over and protection operates during the final Reclaim Time.
- 2) If CBFP failure appeared in relay (if CBFP enable).
- 3) At the end of the each reclaim timer if the CB is in the open position (Close DI is not present).
- 4) If a Close pulse of AR relay is given and the CB fails to close through close DI input or expiry of Trip Contact Sense time.
- 5) If a open pulse given to CB and CB fails to open in between Trip Contact Sense time.

In any of these cases, Manual reset will be required to reinitiate the AR.

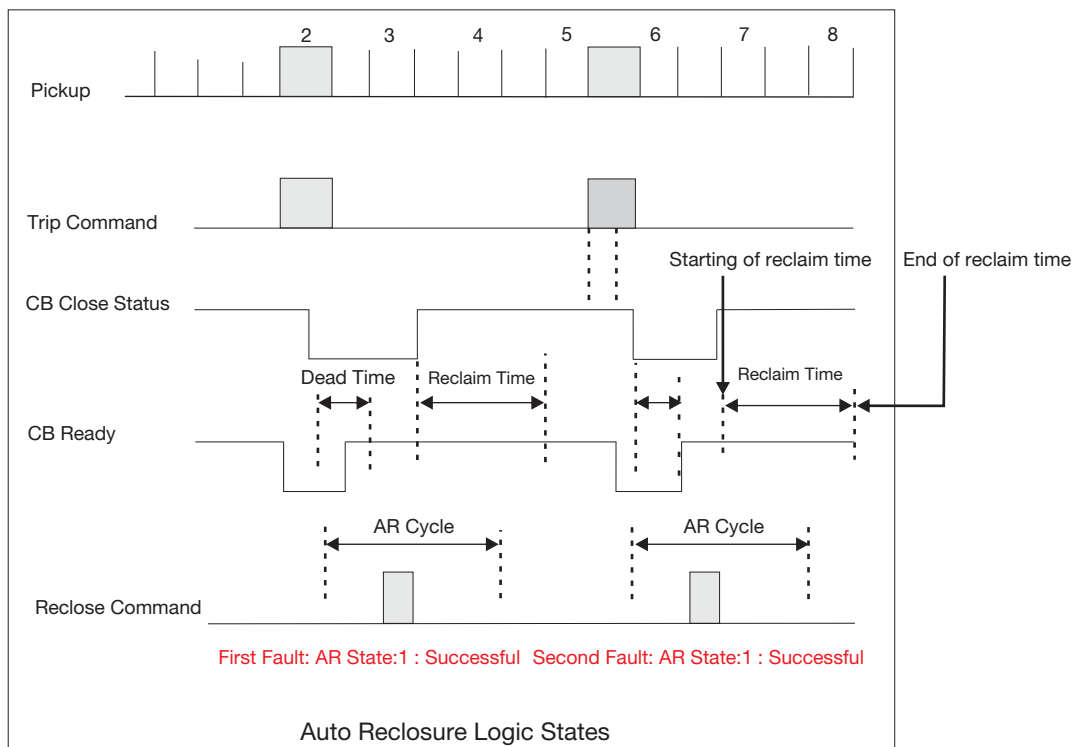

(Figure 2)

Thermal Over load Protection (49)

Thermal overload protection can be applied to prevent damages to the electrical plant equipment when operating at temperatures in excess of the designed maximum withstand. A prolonged over loading causes excessive heating, which may result in premature deterioration of the insulation or in extreme cases, insulation failure.

CSENEX-I relays incorporate a current based thermal replica, using load current to reproduce the heating and cooling of the equipment to be protected. The element thermal overload protection can be set with both alarm and trip stages.

The heating within any plant equipment, such as cables or transformers, is of resistive type ($I^2R \times t$), thus the quantity of heat generated is directly proportional to current squared (I^2). The thermal time characteristics used in the relay is based on current squared, integrated over time.

The CSENEX-I relays automatically use the highest phase current as input information for the thermal model.

The thermal time characteristic is given by following formula:-

The formula for calculating the trip characteristics is as follows:

$$\text{Trip time (taus)} = \tau \cdot \ln \left[\frac{\left(\frac{I^2}{I_b^2} \right) - p^2}{\left(\frac{I^2}{I_b^2} \right) - k^2} \right] \quad \text{for } p^2 < \frac{I^2}{(I_b^2)} \text{ and } p^2 \leq k^2$$

with τ = thermal time constant of the object to be protected.

I_b = Basic current

I_p = Initial load current

p = Initial load factor ($p=0$ means cold operating component)

k = constant

for thermal characteristics user has two choices

Thermal is based on highest measured RMS current

In CSENEX-I relay three modes are available for saving of thermal memory during power reset. These modes are programmable.

M1 : On Power Reset thermal memory becomes 0.

M2 : On Power Reset thermal memory starts from the same value as at the time of Power Off.

M3 : On Power Reset thermal memory subtracts for the time it is in Off state & starts from the remaining value.

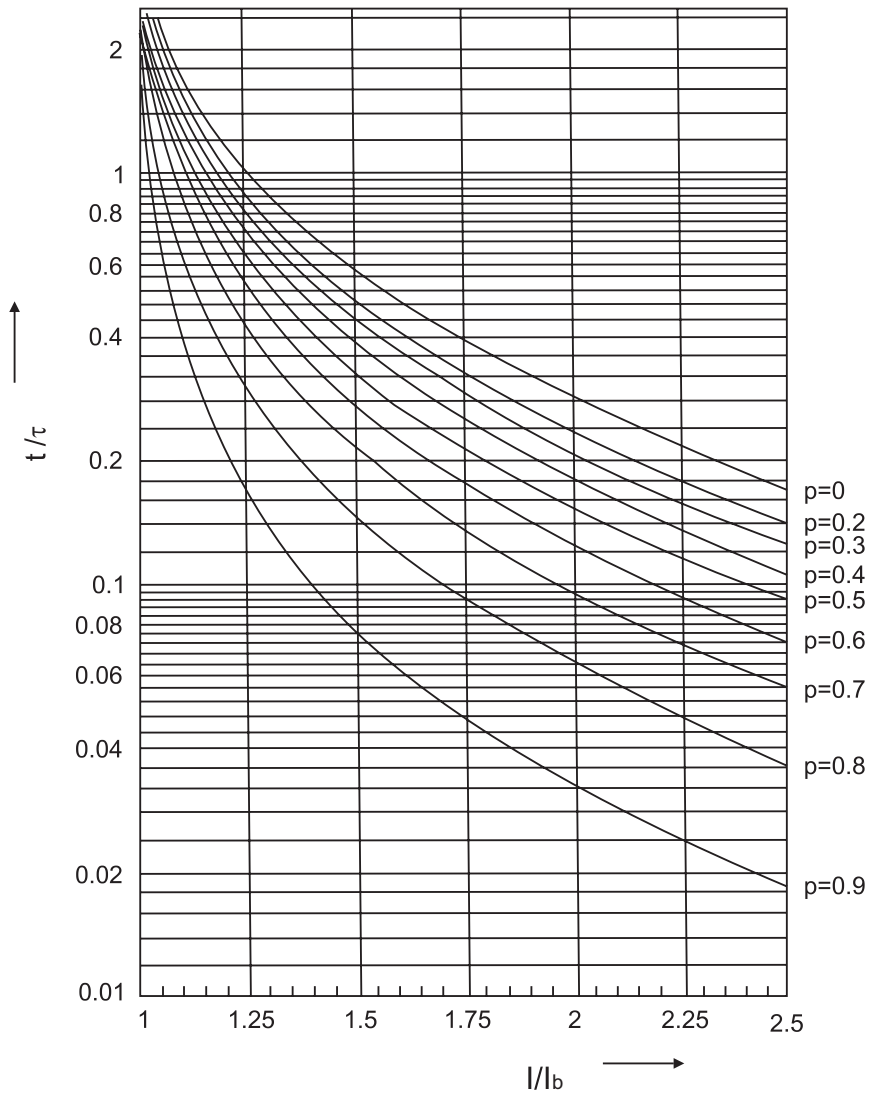

Cold Load Pickup (62 CLD)

This function aims to avoid non-desired trips in the following situation: after being the line de-energized for a period of time and re-energized later, the load exceed the protection setting without the presence of a fault. This may be due to the fact that the “off” period of all the loads (furnaces, heaters, coolers etc.) is elapse and they are all connected at the same time, producing a strong inrush current in the line, but which can be supported within certain time. This phenomenon can occur not only at the moment of the breaker manual closing, after having remained open for a certain time, but also with the breaker permanently closed due to the operation of another upstream breaker.

What the function does, is detecting when those conditions are given and changing the tripping settings during a programmable time.

The function is activated when the current in the 3 phases is below 0.08A, then the programmed time starts to run to determine that the load is “cold” (this time can be 0, what means that any circuit breaker opening could lead to the cold load situation). Once that time has expired and the current has not exceed again 0.15A, the protection usual setting values are replaced by the cold load pickup ones (cold load group settings). When any of the phase current exceed 0.15A a counter with programmable time starts, during which the setting are the cold load pickup ones (cold load group settings). When expiring this time, the settings are again the usual ones. For settings Refer Cold Load Pickup Table in Setting Ranges.

Supervision Function

Trip Circuit Supervision (74TC)

This feature continuously supervises trip circuit of both pre closing and post closing conditions in circuit breaker. It detects tripping mechanism failure like circuit breakage contact degeneration in wires, contacts and coils.

Note: Trip counter is incremented on the basis of getting trip command from relay and not on the basis of external mechanism (circuit breaker) operation.

CT secondary open supervision

The relay supervise the external wiring between the relay terminals and current transformers (CT) and the CT themselves. further more, this is a safety functions as well. since an open secondary of a CT, causes dangerous voltages.

The CT supervisor function measures phase currents. if one of the three currents drops below I_{minSet} , while another phase current is exceeding the I_{maxSet} , the function will issue an alarm after the operation delay has elapsed. Refer Table 9 for these protection settings.

7) Fault Record

CSENX-I records last 25 faults in its non volatile memory with it's Date & time stamp. Each record has the following information:

Fault Format

[F]IL1 : 00.00A
 [F]IL2 : 00.00A
 [F]IL3 : 00.00A
 [F]Ie : 00.00A
 HOUR MIN : HH:MM
 SEC mSEC : Sec:mSec
 DATE : DD:MM:YY
 F-TYPE : FAULTTYPE

Where

[F][ILx] Magnitude of phase current's.

[F]Ie Magnitude earth fault current's

F-Type Origin of fault (over current etc.)(See Figure 3)

whenever the available memory space is exhausted the new fault automatically over writes the oldest fault. When the relay trips the description of fault in the feeder will appears on the LCD screen automatically and by pressing "i"key one can easily get all the detailed information of that fault.

The user can view the fault record either via the front USB interface software or remotely via the RS-485 communication. (See figure-3)

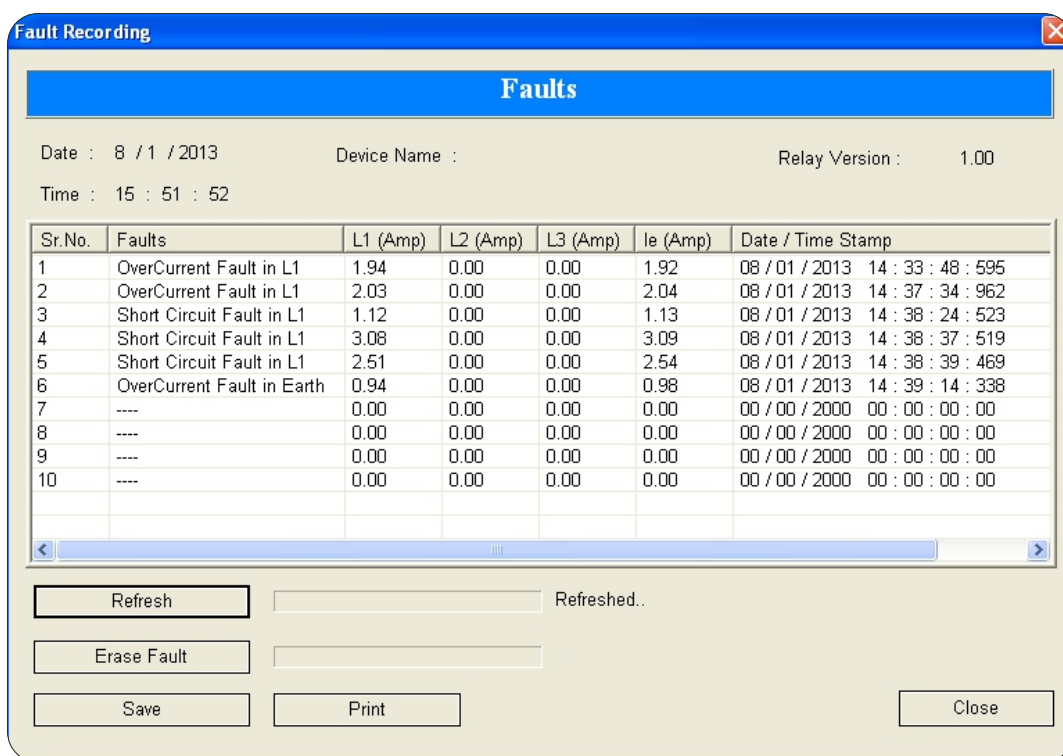

Date : 8 / 1 / 2013 Device Name : Relay Version : 1.00
 Time : 15 : 51 : 52

Sr.No.	Faults	L1 (Amp)	L2 (Amp)	L3 (Amp)	Ie (Amp)	Date / Time Stamp
1	OverCurrent Fault in L1	1.94	0.00	0.00	1.92	08 / 01 / 2013 14 : 33 : 48 : 595
2	OverCurrent Fault in L1	2.03	0.00	0.00	2.04	08 / 01 / 2013 14 : 37 : 34 : 962
3	Short Circuit Fault in L1	1.12	0.00	0.00	1.13	08 / 01 / 2013 14 : 38 : 24 : 523
4	Short Circuit Fault in L1	3.08	0.00	0.00	3.09	08 / 01 / 2013 14 : 38 : 37 : 519
5	Short Circuit Fault in L1	2.51	0.00	0.00	2.54	08 / 01 / 2013 14 : 38 : 39 : 469
6	OverCurrent Fault in Earth	0.94	0.00	0.00	0.98	08 / 01 / 2013 14 : 39 : 14 : 338
7	----	0.00	0.00	0.00	0.00	00 / 00 / 2000 00 : 00 : 00 : 00
8	----	0.00	0.00	0.00	0.00	00 / 00 / 2000 00 : 00 : 00 : 00
9	----	0.00	0.00	0.00	0.00	00 / 00 / 2000 00 : 00 : 00 : 00
10	----	0.00	0.00	0.00	0.00	00 / 00 / 2000 00 : 00 : 00 : 00

Buttons: Refresh, Erase Fault, Save, Print, Close

(Figure 3) (Fault Data Recording on PC software)

8) Event Record

The unit stores in non volatile memory the last 500 events. When the available memory space is exhausted, the new event automatically overwrites the oldest event which can be retrieved from a PC, with the following format:

EVENT : EVENT NUMBER
 HOUR : HH:MM
 SEC mSEC : SEC:mSEC
 DATE : DD/MM/YY

- ❖ Date and time of the event
- ❖ Descriptive text of the even

The user can view event records via the front USB interface software (See Figure 4)

* Description of event number available in event list or in front end software, Pickup & Trip events are recorded.

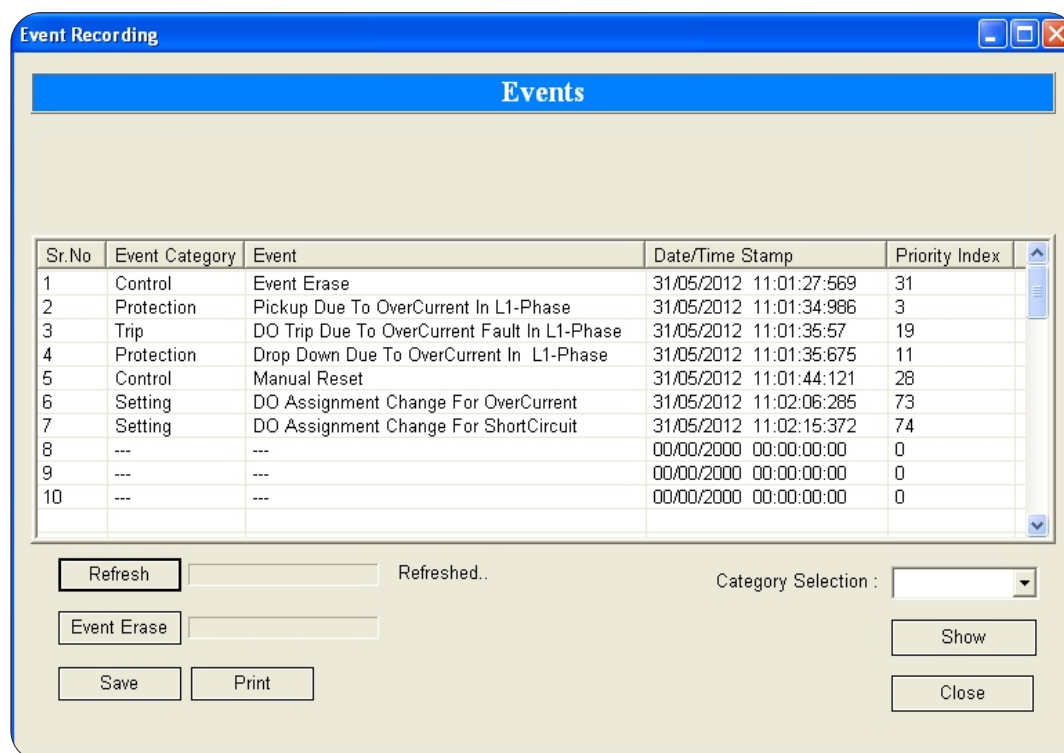

(Figure 4) (Event Data Recording on PC Software)

Output Contacts

No. of Digital outputs : 08 Nos. (configurable)
 Type of outputs : Relay
 Programmable (DO Assignment) : Yes
 Relay reset type : Programmable (Auto/Manual)

Input Contacts

No of Digital inputs : 8 Nos. (configurable)
 Programmable (DI Assignment) : Yes

9) Disturbance Record

The relay has an oscillograph data recorder with the following characteristics:

- ❖ Oscilloscopic recording can trigger on Pickup or on trip or via DI i.e. change from pre-fault to post-fault stage. It is programmable.
- ❖ Each record comprises the samples from 4 analog signals and the status of 8 digital inputs and 8 digital outputs. There will be 30 samples per cycle.
- ❖ Relay saves maximum 1200 cycles, and the number of cycles per record is programmable (for example: if 40 cycles are selected, then there will be maximum 30 records of 40 cycles each).
- ❖ The pre-fault and post-fault cycles are programmable of oscilloscope (disturbance) record setting).
- ❖ Records are in the non volatile memory.
- ❖ The records are transferred to PC using USB interface. The data is graphically displayed & can be taken on printer.
- ❖ Record 1 is always latest record. 2nd record is older than 1st..... and so on.
- ❖ Disturbance record in comtrade format as per IEC60255-24.

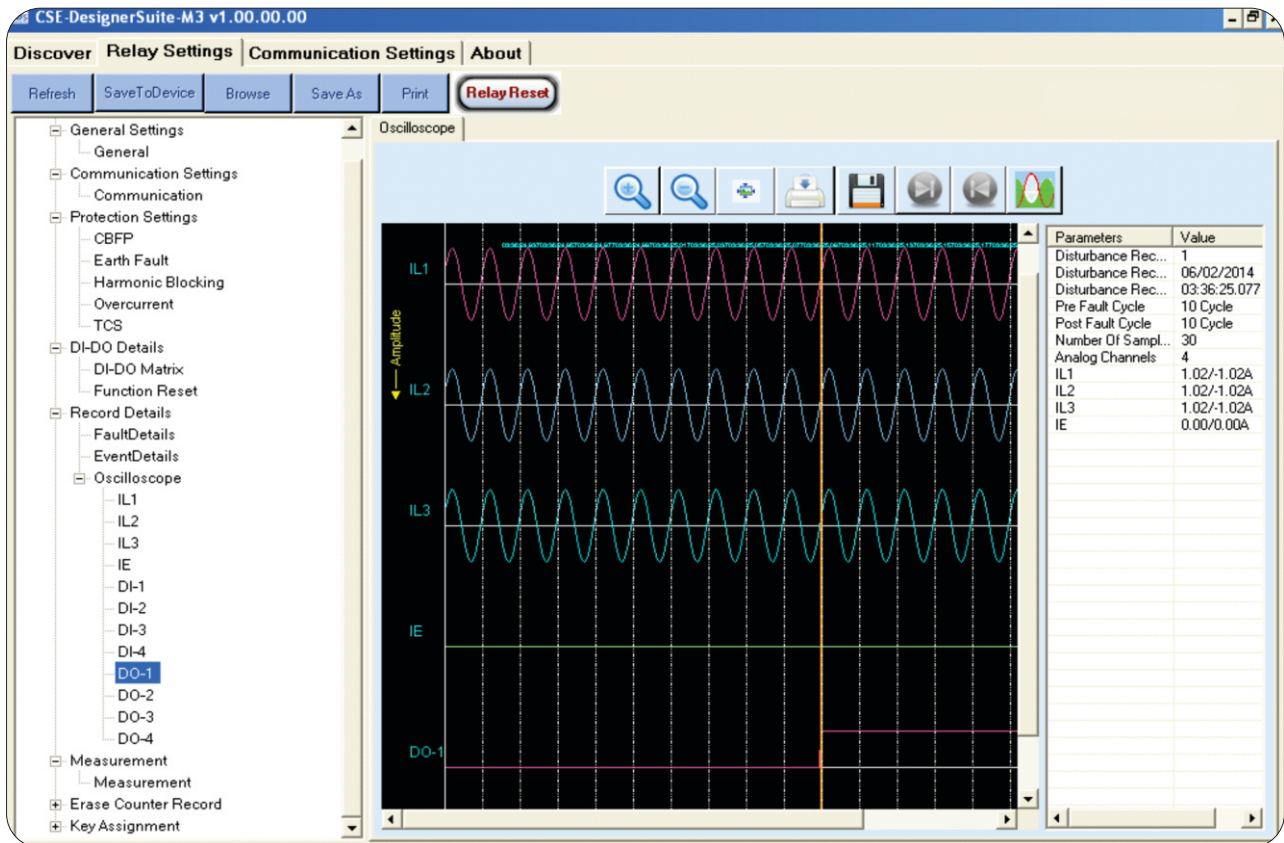

(Figure 5) (Disturbance Recording on PC software)

10) Programmable Scheme Logic

Programmable scheme logic is configured using the front end interface PLC Editor. This interface uses Boolean equations. Flexible logic allows user to create logic diagram to be assigned digital output.

The designed logic is event driven to ensure that protection is not delayed.

The following figure describes the use of protection schemes using the over current pickup & under voltage pickup from downstream relays to block operation of upstream relays using a digital output.

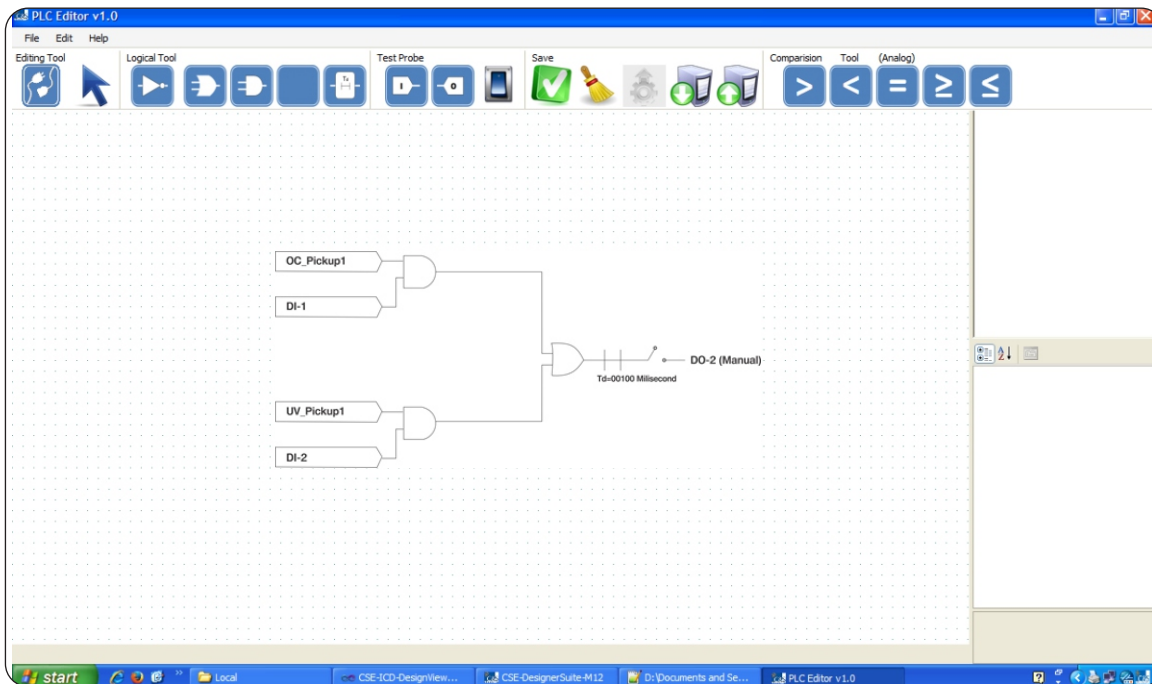

(Figure 6)



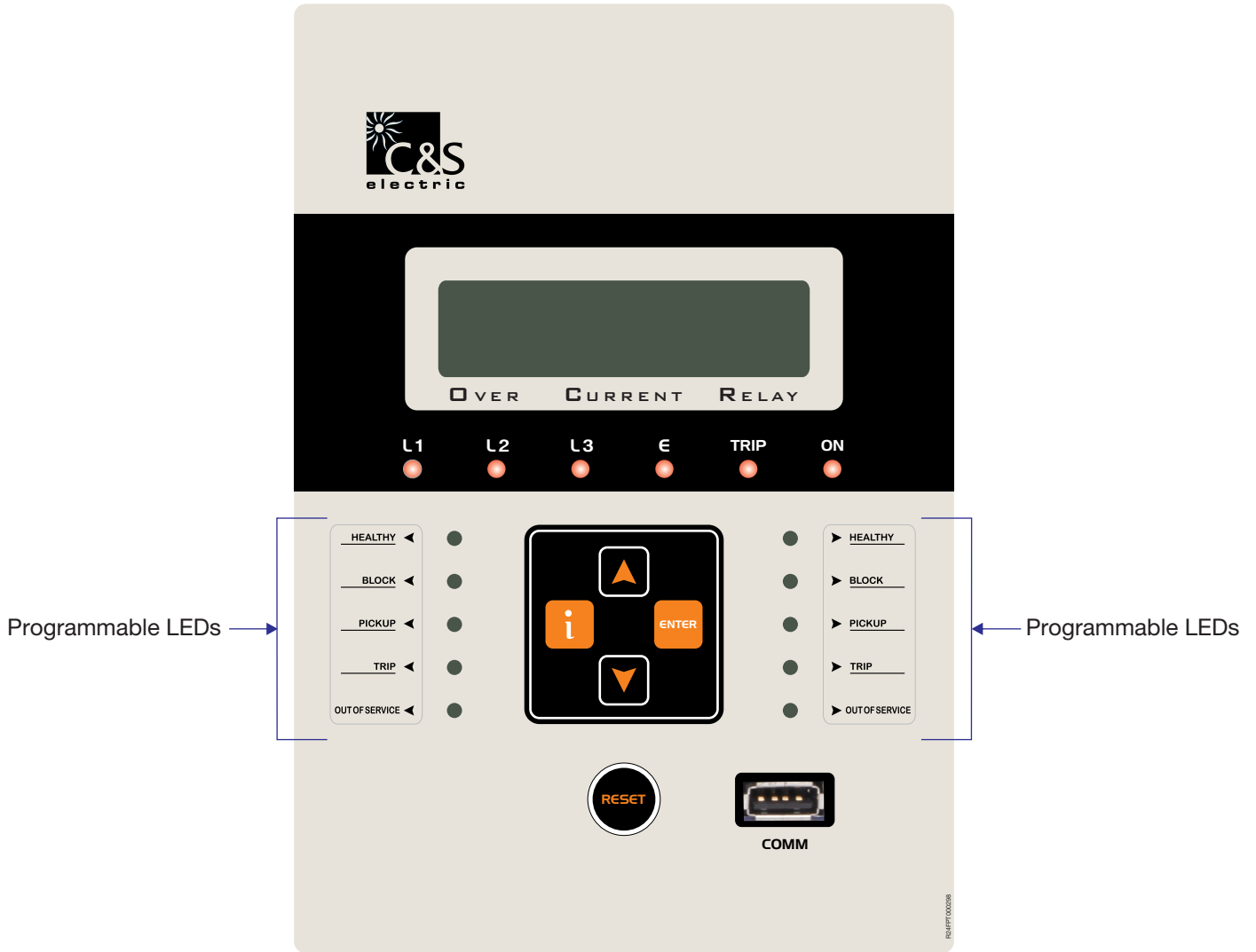

11) Human Machine Interface

It comprises of bright LCD display

- ❖ Four push switches for setting values of normal tripping characteristics and other operations for local access.
- ❖ One 'RESET' push switch.
- ❖ LEDs for pickup or tripping on fault and event in any phase.



(Figure 7)

Keys	Manual Key
	is used as intelligent key to see the details of last fault and Relay status.
	is used as a "ENTER" key.
	is used to manual reset (after pressing for 2 sec).
	is used to scroll in upward direction.
	is used to scroll in downward direction.

12) Communication (Local and Remote)

The unit has:

- ❖ 1 Front USB port for direct connection to a PC
- ❖ 1 Rear RS-485 communication port

12.1) Front Communication

The entire setting, Fault & Event are available on 'A' type USB (female) interface with CSE LIVELINK with saving & printing option. This unit also has Front-end Live Link simulation support for testing of relay even without any three phase injection source.

12.2) Rear Communication

The protocol for the rear port is MODBUS-RTU.

13) Setting Ranges

Phase Over Current Protection (50P/51P)

S.No	Parameter	Display	Setting Range		Step Size	Default Setting
			Min	Max		
1	Phase over-current low set pickup setting	I>	0.05xI _p	4.00xI _p	0.01xI _p	Disable
2	Phase characteristics	PCurve	DEFT/EINV/VINV//LINV/NINV1.3/NINV3.0/NINV0.6			DEFT
3	Phase over-current inverse timing	t _i >	00.01	15.00	00.01	00.10
4	Phase over-current definite timing	t>	000.10s	150.00s	000.01s	000.10s
5	Phase over-current hi-set pickup setting	I>>	00.05xI _p	30.00xI _p	00.01xI _p	Disable
6	Phase over-current hi-set definite timing	t>>	00.02s	20.00s	00.01s	00.10s

$$\text{Very Inverse} \quad t = \frac{13.5}{(I/Is) - 1} \quad t_i \text{ [s]}$$

$$\text{Extremely Inverse} \quad t = \frac{80}{(I/Is)^2 - 1} \quad t_i \text{ [s]}$$

$$\text{Long time Inverse} \quad t = \frac{120}{(I/Is) - 1} \quad t_i \text{ [s]}$$

$$\text{Normal Inverse 3.0/1.3/0.6} \quad t = \frac{0.14/0.061/0.028}{(I/Is)0.02 - 1} \quad t_i \text{ [s]}$$

Where t = Tripping time t_i = Time multiplier
 I = Fault current Is = Setting value of current

Trip timing Accuracy : DEFT/ NINV 0.6 / NINV 3.0 / 1.3 : $\pm 5\%$ OR $\pm 30\text{mSec}$ (whichever is higher)
 EINV / VINV / LINV : $\pm 7.5\%$ OR $\pm 40\text{mSec}$ (whichever is higher)

Cold Load Protection (62 CLD)

S.No	Parameter	Display	Setting Range		Step Size	Default Setting
			Min	Max		
1	Cold Load Pickup	CLP PKUP	Enable	Disabl	-----	Disable
2	Cold Load Time	tcold	0.00s	100.00s	-----	0.10s
3	Cold Load Pickup Time	tclp	0.00s	100.00s	-----	0.10s
4	Phase over-current low set pickup setting	I>	0.05xI _p	4.0xI _p	0.01xI _p	Disable
5	Phase characteristics	PCurve	DEFT/EINV/VINV//LINV/NINV1.3/NINV3.0/NINV0.6			DEFT
6	Phase over-current inverse timing	tI>	0.01	15.0	0.01	0.10
7	Phase over-current definite timing	t>	0.05s	150.00s	0.01s	0.10s
8	Phase over-current hi-set pickup setting	I>>	0.05xI _p	30xI _p	0.01xI _p	Disable
9	Phase over-current hi-set definite timing	t>>	0.02s	20.00s	0.01s	0.10s
10	Earth over-current low set pickup setting	Ie>	0.05xI _n	2.5xI _n	0.01xI _n	Disable
11	Earth Characteristics	ECurve	DEFT/EINV/VINV/LINV/NINV1.3/NINV3.0/NINV0.6			DEFT
12	Earth over-current low set inverse timing	tIe>	0.01	15.0	0.01	0.10
13	Earth over-current low set definite timing	tIe>	0.03s	150.00s	0.01s	0.10s
14	Earth over-current hi-set pickup setting	Ie>>	0.05xI _n	20xI _n	0.01xI _n	Disable
15	Earth over-current hi-set definite timing	tIe>>	0.02s	20.00s	0.01 Sec	0.10s

Trip Circuit Supervision Protection (74TC)

S.No.	Parameter	Display	Setting Range		Step Size	Default Setting
			Min.	Max.		
1	TCS	td	0.03s	2.00s	0.01s	Disable

Negative Phase Protection Setting

S.No.	Parameter	Display	Setting Range		Step Size	Default Setting
			Min.	Max.		
1	Enable NPS	Enable	NO	YES	-----	YES
2	NPS characteristics	Char	DEFT	NPS-INV	-----	DEFT
3	Pick up current	I _b	0.10xI _p	2.5xI _p	0.01xI _p	0.10xI _p
4	Time multiple	K1	5.0	600	1.0	5 Sec
5	Definite time	td	0.10	600	0.10	0.20 Sec

Circuit Breaker Failure Protection (50BF)

S.No.	Parameter	Display	Setting Range		Step Size	Default Setting
			Min.	Max.		
1	CBFP	tCBFP	0.03s	2.00s	0.01s	Disable

Earth Setting (50N/51N)

S.No	Parameter	Display	Setting Range		Step Size	Default Setting
			Min	Max		
1	Earth over-current low set pickup setting	le>	0.05xIn	2.50xIn	0.01xIn	Disable
2	Earth Characteristics	ECurve	DEFT/EINV/VINV/LINV/NINV1.3/NINV3.0/NINV0.6			DEFT
3	Earth over-current low set inverse timing	tie>	0.01	15.00	00.01	00.10
4	Earth over-current low set definite timing	te>	0.03s	150.00sc	000.01s	000.10s
5	Earth over-current hi-set pickup setting	le>>	0.05xIn	20.00xIn	00.01xIn	Disable
6	Earth over-current hi-set definite timing	te>>	00.02s	20.00s	00.01s	00.10s

Auto Re-closer Mode (79)

S.No.	Parameter	Display	Setting Range		Step Size	Default Setting
			Min.	Max.		
1	Enable Auto-recloser	Enable	YES	NO	-----	NO
2	Dead time 1	D1	000.20s	300.00s	0.01s	0.20s
3	Dead time 2	D2	000.20s	300.00s	0.01s	0.20s
4	Dead time 3	D3	000.20s	300.00s	0.01s	0.20s
5	Dead time 4	D4	000.20s	300.00s	0.01s	0.20s
6	Reclaim time	tR	000.20s	300.00s	0.01s	0.20s
7	Phase over-current low set max AR cycle	Cyc l>	2	4	1	2
8	Phase over-current hi-set max AR cycle	Cyc l>>	2	4	1	2
9	Earth over-current low set max AR cycle	Cyc le>	2	4	1	2
10	Earth over-current hi-set max AR cycle	Cyc le>>	2	4	1	2
11	Trip sense time	t_TST	0.05s	2.00s	0.01s	0.05s

Thermal Over load (49)

S.No.	Parameters	Display	Setting Range		Step Size	Default Setting
			Min	Max		
1	Thermal memory	MemMod	M1	M3	1.0	M1
2	Permissible basic current	lb	0.20xlp	4.00xlp	0.02xlp	Disable
3	Constant	k	0.50	2.00	0.01	1.00
4	Heating time constant	Th	000.5min	180.0min	000.1min	000.5min
5	Cooling constant	Tc	1.00xTh	8.00xTh	0.01xTh	1.00xTh
6	Thermal alarm	Alrm_R	20%	99%	1%	20%
7	Thermal reset	TH_Rst	00%	99%	1%	70%

Harmonic Setting (51H)

S.No.	Parameter	Display	Setting Range		Step Size	Default Setting
			Min.	Max.		
1	Phase 2nd Harmonic	P2ndH	10%If	50%If	1%If	Disable
2	Phase 3rd Harmonic	P3rdH	10%If	50%If	1%If	Disable
3	Earth 2nd Harmonic	E2ndH	10%If	50%If	1%If	Disable
4	Earth 3rd Harmonic	E3rdH	10%If	50%If	1%If	Disable
5	tPHASE	tPHASE	0.0 Sec	20 Sec	0.1	00.00s
6	tEARTH	tEARTH	0.0 Sec	20 Sec	0.1	00.00s

Oscilloscope (Disturbance) Record

S. No.	Parameters	Display	Setting Range		Step Size	Default Setting
			Min	Max		
1	Oscilloscope record	RECORD	NO	YES	-	NO
2	Pre-fault cycle	PRE CYCLE	002C	298C	1C	002C
3	Post-fault cycle	POST CYCL	002C	298C	1C	002C
4	Triggering mode	TRIG MODE	PK-UP	PK-UP/TRIP/DI/ Anyon	-	PK-UP

DO Assignment

S.No	Parameter	Display	Setting Range	
			Min.	Max.
1	Phase over-current low set	I>	---	12345678
2	Phase over-current hi-set	I>>	---	12345678
3	Earth over-current low set	Ie>	---	12345678
4	Earth over-current hi-set	Ie>>	---	12345678
5	Trip circuit supervision	TCS	---	12345678
6	Circuit breaker failure	CBFP	---	12345678
7	Self supervision	SELFSU	---	12345678
8	Auto Re-closer Relay	ARcls	---	12345678
9	Lockout relay	ARlck	---	12345678
10	Circuit breaker open	CBopn	---	12345678
11	Circuit breaker close	CBcls	---	12345678
12	Remote Trip	Rmt tp	---	12345678
13	Thermal Relay	THrly	---	12345678
14	Thermal Alarm	THalm	---	12345678
15	NPS Over current	I2>	---	12345678

DI Assignment

S.No	Parameter	Display	Setting Range	
			Min.	Max.
1	CB Close	CB Cls	---	12345678
2	CB Open	CB Opn	---	12345678
3	CB Ready	CB Rdy	---	12345678
4	Remote Trip	Rmt tp	---	12345678
5	Group toggling	GRP tg	—	12345678
6	Remote Reset	RMT Rt	—	12345678
7	Oscilloscope Toggling	OSC Tg	—	12345678
8	Phase Over current Lo-set Blocking	I> BLK	—	12345678
9	Phase Over current Hi-set Blocking	I>> BK	---	12345678
10	Earth Over current Lo-set Blocking	E> BLK	—	12345678
11	Earth Over current Hi-set Blocking	E>> BK	---	12345678
12	Auto Reclose blocking	AR BLK	—	12345678
13	Thermal Blocking	Th BLK	—	12345678
14	Cold Load Blocking	Cld BLK	—	12345678
15	NPS Blocking	NpsBLK	—	12345678

Function Reset

S.No.	Parameter	Display	Setting Range		Default Setting
			Min.	Max.	
1	Phase over-current low set	I>	AUTO	MANUAL	AUTO
2	Phase over-current hi set	I>>	AUTO	MANUAL	AUTO
3	Earth over-current low set	Ie>	AUTO	MANUAL	AUTO
4	Earth over-current hi set	Ie>>	AUTO	MANUAL	AUTO
5	Trip Circuit Supervision	TCS	AUTO	MANUAL	AUTO
6	Remote Trip	Rmt Trip	AUTO	MANUAL	AUTO
7	Auto recloser	AR Close	AUTO	MANUAL	AUTO
8	Thermal Trip	Thm Trip	AUTO	MANUAL	AUTO
9	Thermal Alarm	Thm Alrm	AUTO	MANUAL	AUTO
10	Negative Phase Sequence	I2>	AUTO	MANUAL	AUTO

Erase Record

S.No.	Parameter	Display	Setting Range		Default Setting
			Min.	Max.	
1	Trip Count Record	Trip_Cntr	NO	YES	NO
2	Thermal Reset	ThrmLRset	NO	YES	NO
3	Event Erase Record	EventsErase	NO	YES	NO
4	Fault Erase Record	FaultsErase	NO	YES	NO
5	Oscilloscope Record Erase	OscRcrdEras	NO	YES	NO

Date & Time Setting

S.No.	Parameters	Display	Setting Range		Step Size
			Min	Max	
1	Hour	HOUR	00	23	1
2	Minute	MIN	00	59	1
3	Second	SEC	00	59	1
4	Date	DATE	1	31	1
5	Day	DAY	SUN	SAT	1
6	Month	MONTH	Jan	Dec	1
7	Year	YEAR(2000 Y)	00	99	1

Common Setting

S.No.	Parameter	Display	Setting Range		Step Size	Default Setting
			Min.	Max.		
1	Rated Phase Current	Ip	1.00A	5.00A	-----	1.00A
2	Rated Earth Current	In	1.00A	5.00A	-----	1.00A
3	Phase CT Ratio	Ph CTR	0001	9999	1	1
4	Earth CT Ratio	E CTR	0001	9999	1	1
5	Nominal Frequency	FREQ (Fn)	50 Hz	60 Hz	-----	50 Hz
6	Fault Status	FStat	Enable	Disable	-----	Disable

Active Group Setting

S.No.	Parameters	Display	Setting Range		Step Size	Default Setting
			Min	Max		
1	Active Group	ACTIVE	GROUP1	GROUP2	-	GROUP1

Front USB Port

USB Communication Protocol	CSE proprietary protocol available with front software
Baud rate	19200 bps
Cable required for interface	USB cable type (A to A)

Rear Port Communication

RS-485 Communication	
Baud rate selection (programmable)	9600/19200/38400 bps
Parity selection (programmable)	None / Even / Odd
Protocol	MODBUS RTU / IEC-103
Slave Address (programmable)	(1 to 247)

Auxiliary Supply

Auxiliary Voltage Range	For 'L' Model	18V-60V DC
	For 'H' Model	85V-280V AC / 90V-300V DC
	For 'W' Model	18V-160V DC
Power Consumption		Quiescent approx. 3W
		Operating approx. <7W
Rated Supply for Digital Input	For 'L' Model	18V-150V DC (Active)
		<10V DC (Inactive)
	For 'H' Model	40V-280V AC (Active)
		40V-300V DC (Active) <25V AC/DC (Inactive)

Measurement Accuracy

S.No	Quantity	Range	Frequency Range	Accuracy
1	Current	1 - 30 xlp	50 - 60 Hz	±2%

Pickup Accuracy

S.No	Quantity	Range	Frequency Range	Accuracy
1	Current	1 - 30 xlp	50 - 60 Hz	+5% of Pickup setting

14) Technical Data

Measuring Input

Rated Data	Rated current I_p : 1A or 5A Rated frequency F_n : 50 Hz/60Hz
Drop out to Pickup Ratio	>96%
Reset Time	30mSec
Power consumption in current circuit	At $I_p=1A$ 0.1 VA At $I_p=5A$ 0.2 VA
Thermal withstand capability in current circuit	Dynamic current withstand for 1 Sec : 100 x I_p for 10 Sec : 30 x I_p continuously : 4 x I_p

Trip Contact Rating

Contact Rating	
Contact relay	Dry contact Ag Ni
Make current	Max. 30A & carry for 3S
Carry capacity	8A continuous : Relay 1, Relay 2
	5A continuous : Relay 3, 4, 5, 6, 7, 8
Rated voltage	250V AC/ 30V DC
Breaking Characteristics	
Breaking capacity AC	1500VA resistive
	1500VA inductive (PF=0.5)
Breaking capacity DC	220V AC, 5A (cos ϕ <=0.6)
	135V DC, 0.3A (L/R=30ms)
	250V DC, 50W resistive or
	25W inductive (L/R=40ms)
Operation time	<10ms
Durability	
Loaded contact	10000 operation minimum
Unloaded contact	30000 operation minimum

15) Specification Table of I-450

Function	ANSI	NEX-I 450
CT inputs	-	4
PT Inputs	-	x
Over current	50/51	✓
Earth Fault	50N/51N	✓
CBFP	50BF	✓
Trip Circuit	74TC	✓
Harmonic Blocking	51H	✓
Cold Load Pickup	62 CLD	✓
Self Supervision	-	✓
CT Supervision	-	✓
Negative Phase Sequence	46	✓
Programmable Scheme Logic	-	✓
Auto Re-closer	79	✓
Thermal Over-load	49	✓
Fault Record	-	25
Event Record	-	500
Disturbance Record	-	✓
Selection of 1/5A	-	Site selectable
Digital Input	-	8
Digital Output	-	8
Enclosure Type	-	Draw out with CT shorting
Front Communication	-	✓
Rear Communication (RS-485)	-	✓

16) Standards

Type Test			
F1	Functional Tests	Internal Design	Performance in line with Specification & Standards
		Specifications & IEC60255-6 IEC60255-3	Pickup/Drop down/Power consumption in Current/Voltage/Aux Supply/Trip timing accuracy: OC/ Directional/NPS/Thermal/OV/Zero Seq/Over Power/ freq/Rate of change of Freq

Climatic Test			
C1	Temperature Dry Cold (Relay operational)	IEC 60068-2-1	-20 deg C, 96 hours
C2	Temperature Dry Cold Transportation & Storage	IEC 60068-2-1	-25 deg C, 96 hours
C3	Temperature Dry Heat (Relay operational)	IEC 60068-2-2	55 deg C, 96 hours
C4	Temperature Dry Heat Transportation & Storage	IEC 60068-2-2	70 deg C, 96 hours
C5	Damp Heat Test (Relay operational)	IEC 60068-2-3	95% @ +55 / +25 deg C, 6 cycle (12hr + 12hr each)

Enclosure			
C6	Enclosure	IEC 529	Front Ip54 (Dust 5x + Water x4)

Mechanical Test

Relay Operational			
M1	Vibration response / Endurance test	IEC 60255-21-1	Class I Vibration response (Relay operational) 10Hz~150 Hz - peak displacement 0.035 mm below 58/60 Hz, 0.5 g above, 1 sweep cycle in each axis Vibration endurance (Relay de-energised) 10 Hz~150 Hz 1g, 20 sweep cycles in each axis
M2	Shock Response / Withstand Test	IEC 60255-21-1	Class I Shock response (Relay operational) 5g 11mS 3 pulse in each axis Shock withstand (Relay de-energised) 15g 11mS 3 pulses in each axis
M3	Bump	IEC 60255-21-1	Bump (Relay de-energised) 10g 16mS 1000 pulses in each axis
M4	Seismic	IEC 60255-21-3	Class I Method A single axis sine sweep 1 Hz~35 Hz~below 8/9 Hz 3.5 mm peak displacement horizontal axis, 1.5 mm vertical axis above 8/9 Hz 1g horizontal, 0.5 g vertical 1 sweep cycle in each axis

Electrical Test			
E1	Insulation Resistance >100MΩ	IEC 60255-5	500V DC, 5 sec between all terminals & case earth, between terminals of independent circuits including contact circuits and across open contacts
E2	DC & AC Supply Voltage (Relay operational)		IEC 60255-6 Voltage range, upper & lower limit continuous withstand, ramp up & down over 1 minute
E3	Voltage Dips, Short Interruptions & Voltage variations immunity (Relay operational)	IEC 1000-4-11	IEC 60255-113 Dips & 3 Interruptions at 10 sec intervals of duration between 10mS and 500mS at zero crossings & at other points on wave Variation: 100% to 40% over 2s, hold for 1s, return to 100% over 2s
E4	Ripple in DC supply (Relay operational)	IEC 60255-11	12% AC ripple
E5	Dielectric Test (Relay de-energised) No breakdown or flash over Test voltage 45-65 Hz sinusoidal or with DC voltage at 1.4x the stated AC values	IEC 60255-5	2.0 KV @ 1min All circuit to Earth / Between IP & OP
E6	High Voltage Impulse (Relay de-energised)	IEC 60255-5	5 kV peak 1.2/50uS, 0.5 J-3 positive, 3 negative between all terminals to case earth between independent circuits
E7	VT Input Thermal Withstand		1.5xVn, continuous
E8	CT Input Thermal Withstand		250xIn half wave 100xIn for 1 second 30xIn for 10 second 4xIn continuously
E9	Contact performance & endurance tests	IEC 60255-14,15 IEC 60255-23	

Electro-magnetic Compatibility			
R1	Electrical fast Transient/Burst (Relay operational)	IEC 60255-22-4 IEC 60100-4-4	Class IV- ± 4.0 kV All Circuits. Pulse 5/50nsec/Duration 15msec/ Period: 300msec/Pulse Freq: 5KHz / 2KV at I/O
R2	HF Disturbance Test (Oscillatory Waves) 1 MHz Burst (Relay operational)	IEC 60255-22-1	Class III Longitudinal 2.5 kV peak, 2sec between independent circuits & case earth
R3	Electrostatic Discharge (Relay operational)	IEC 60255-22-2 IEC 61000-4-2	Class III 8kV air discharge, 6KV contact No of Discharge : 10 both polarities at 1 sec intervals
R4	Conducted Disturbance RF fields (Relay operational)	IEC 61000-4-6 IEC 60255-22-6	0.15 to 80 MHz (Level-3) Severity Level 10V RMS + sweeps 0.05-0.15 MHz & 80-100 MHz
R6	Radiated RF E-M field immunity test (Relay operational)	IEC 60255-22-3 IEC 61000-4-3	Class III Test method A + sweep 80-1000 MHZ or IEC 1000-4-3 80-1000 MHZ severity 10 V/m 80% modulated 1 kHz
R7	Surge Immunity capacitively coupled (Relay operational)	IEC 61000-4-5 Class 5 Test level 4 IEC 60255-22-5: 2008 Latest: IEC 60255-26:2013	Short circuit combination wave generator 1.2 uS/50 uS open circuit repetition rate 1 per minute Power supply, CT & VT circuits – 4kV common mode 2 Ohm source 2kV differential mode 12 Ohm source
R8	Power Frequency Magnetic Field (Relay operational)	IEC 61000-4-8	100 A/m for 1 minute in each of 3 axes
R14	Conducted & Radiated RF Interference Emission (Relay operational)	EN55011 IEC 60255-25	CISPR11/ Class A
R15	Power Frequency, conducted common mode	IEC 1000-4-16 IEC 60255-22-7	D.C. to 150 kHz Test Level 4 300V at 16 2/3 Hz and 50 Hz

17) Recommended Terminal Lugs Specifications

Term Blocks	Type/Cable Specifications
Current Inputs	Ring Type lug / 2.5mm ² or 4 mm ² control cable
Auxiliary Supply	Pin Type lug / 1.5 mm ² / 2.5 mm ² control cable
Rear Comm. Port	Pin Type lug / 1.5 mm ² / 2.5 mm ² control cable
Front Comm. Port	USB, Type A
Binary Input	Pin Type lug / 1.5mm ² / 2.5mm ² control cable
Binary Output	Pin Type lug / 4.0mm ² control cable
Earth Connections	Ring Type / 2.5mm ² or 4 mm ² contact cable



Cable required for Front USB Communication (Type A to A)



(Figure 8)

18) Connection Diagram

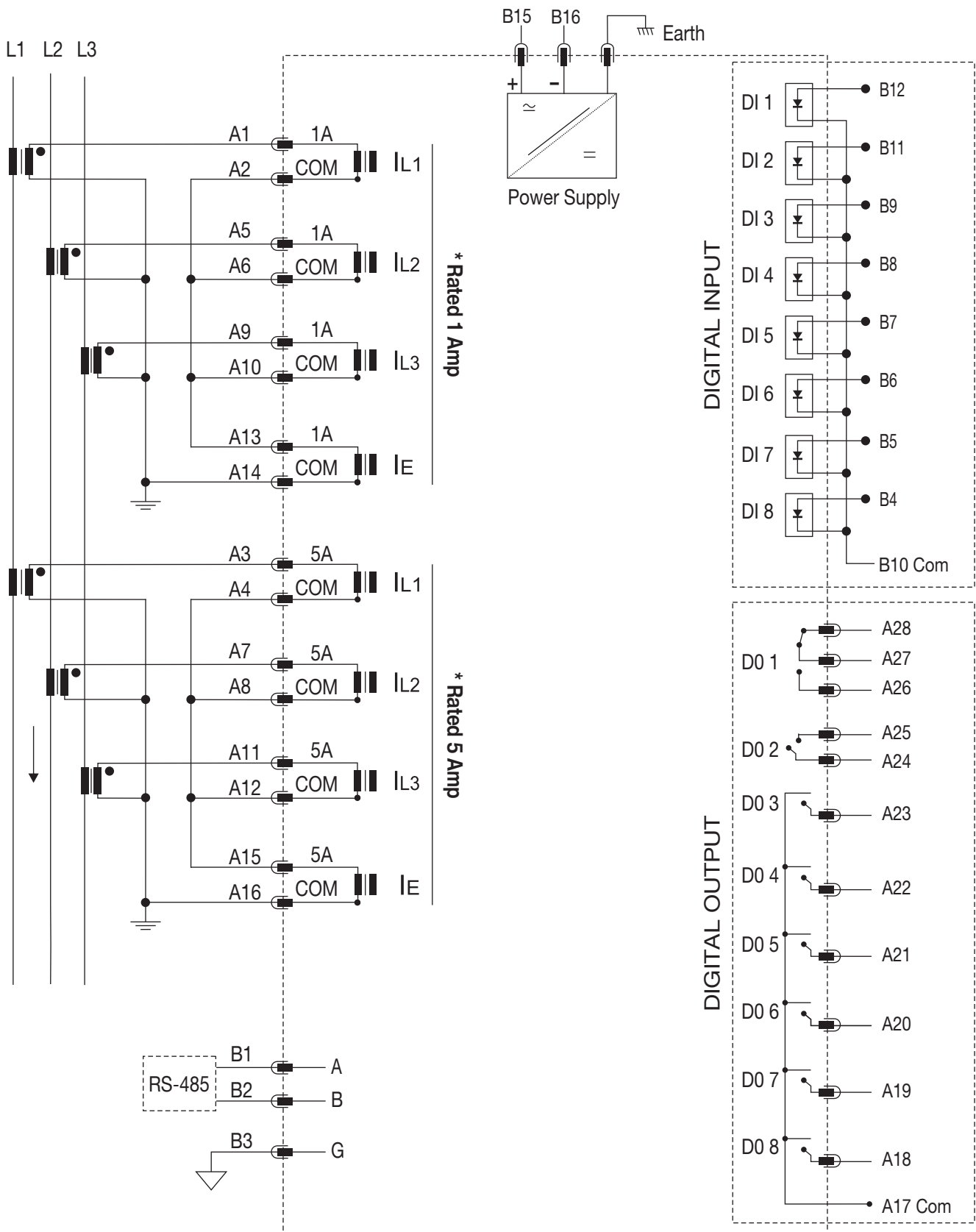

CSENEX-I for 8 DIs & 8 DOs

(Figure 9)

19) Terminal Description (for 8 DI & 8 DO)

Term Name	Terminal Description
A1-A2	CT Terminal for Phase current input (1A) in L1 Phase
A5-A6	CT Terminal for Phase current input (1A) in L2 Phase
A9-A10	CT Terminal for Phase current input (1A) in L3 Phase
A13-A14	CT Terminal for Phase current input (1A) in Neutral current
A3-A4	CT Terminal for Phase current input (5A) in L1 Phase
A7-A8	CT Terminal for Phase current input (5A) in L2 Phase
A11-A12	CT Terminal for Phase current input (5A) in L3 Phase
A15-A16	CT Terminal for Phase current input (5A) in Neutral current
A18-A17	Digital Output (DO-8) (NO-COM)
A19-A17	Digital Output (DO-7) (NO-COM)
A20-A17	Digital Output (DO-6) (NO-COM)
A21-A17	Digital Output (DO-5) (NO-COM)
A22-A17	Digital Output (DO-4) (NO-COM)
A23-A17	Digital Output (DO-3) (NO-COM)
A25-A24	Digital Output (DO-2) (NO-COM)
A28-A27-A26	Digital Output (DO-1) (NC-COM-NO)
B1-B2	RS-485 (A), RS-485 (B)
B3	RS-485 Ground
B4-B10	Digital Input (DI-8)
B5-B10	Digital Input (DI-7)
B6-B10	Digital Input (DI-6)
B7-B10	Digital Input (DI-5)
B8-B10	Digital Input (DI-4)
B9-B10	Digital Input (DI-3)
B11-B10	Digital Input (DI-2)
B12-B10	Digital Input (DI-1)
B15-B16	Aux supply (B15: '+' B16: '-')

20) Dimensional Details

All the Dimension are in mm (Gen Tol.: ± 1 mm)

Front View

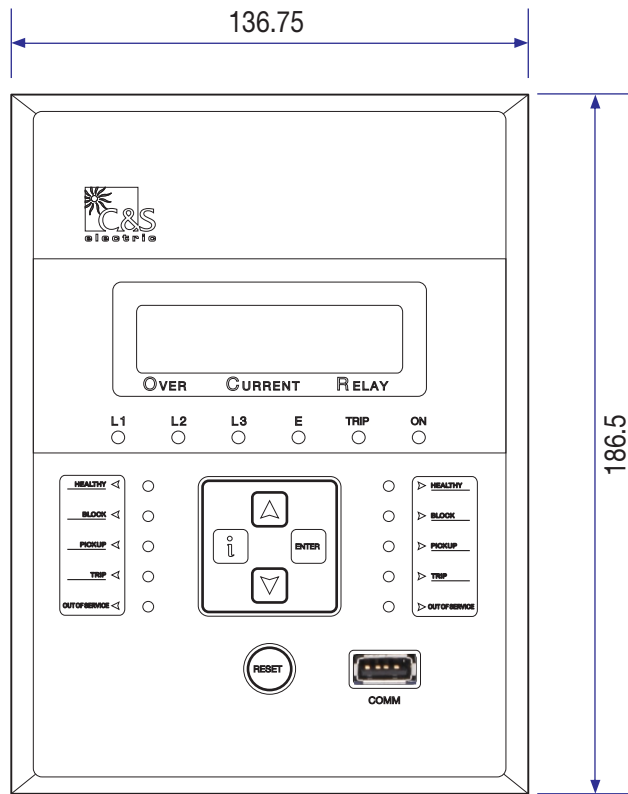

(Figure 10)

Side View

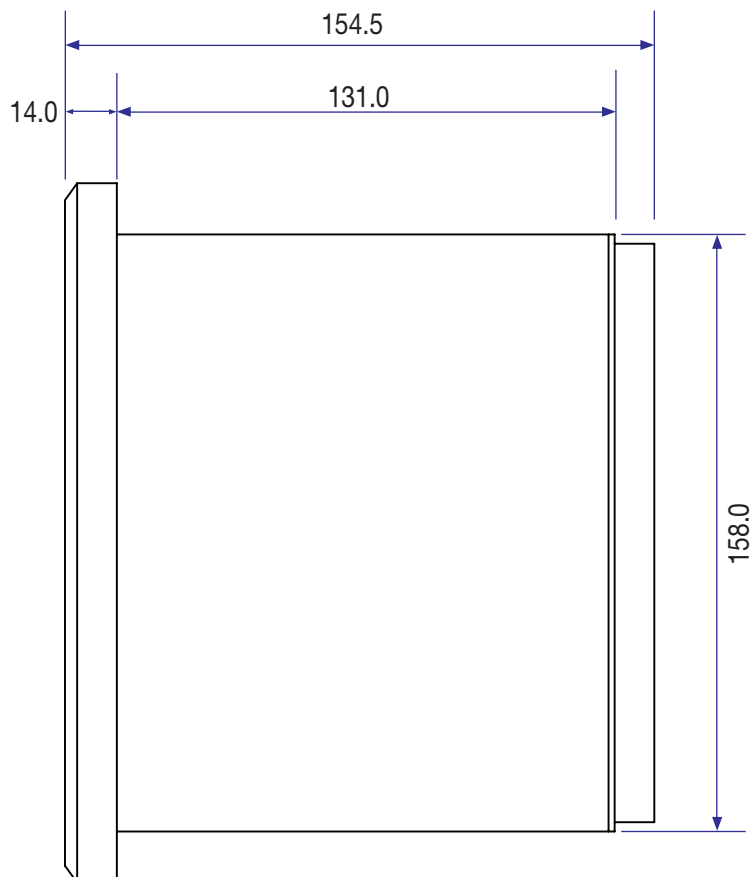

(Figure 11)

Dimensional Details contd..

Top View

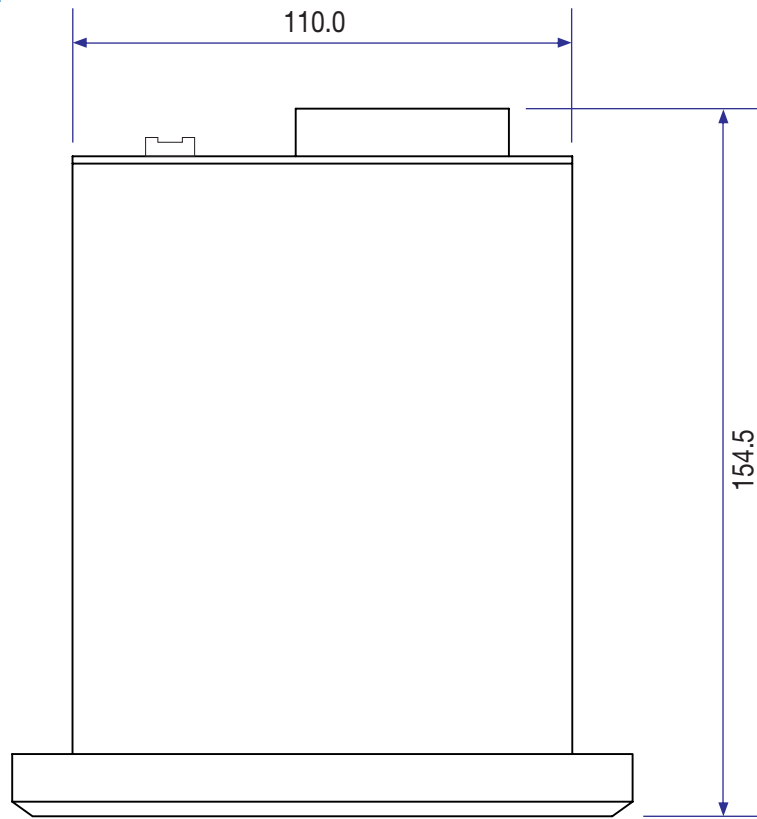

(Figure 12)

Back View

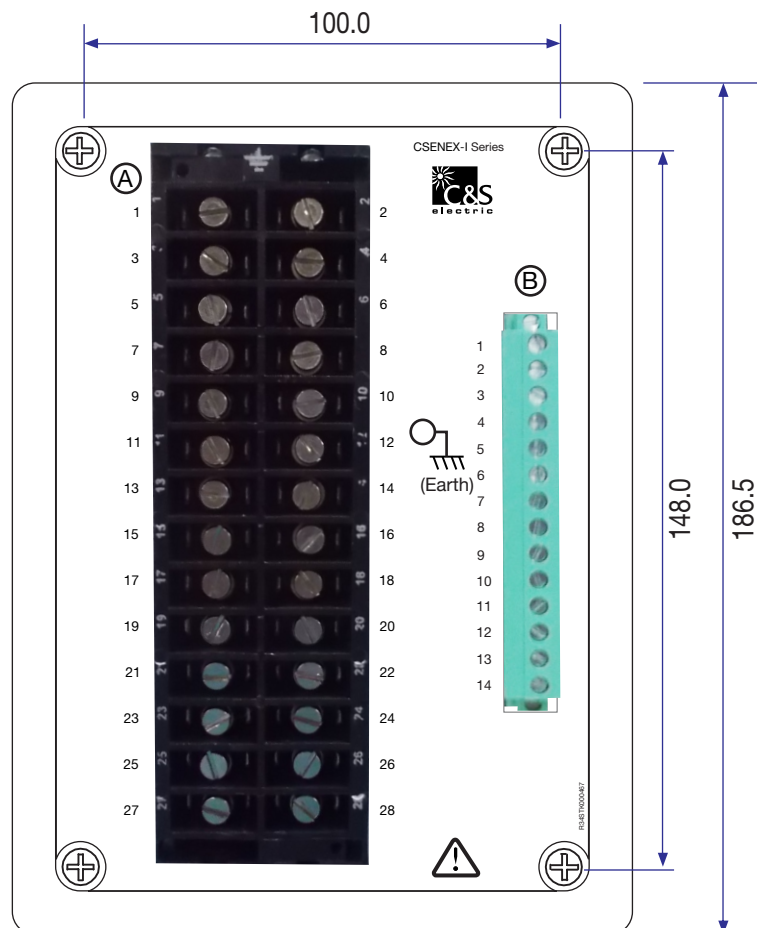

(Figure 13)

21) Panel Mounting Details

Panel cut out Dimension: HeightxWidth=160x112mm

Screw : M3

Qty : 04 Nos.

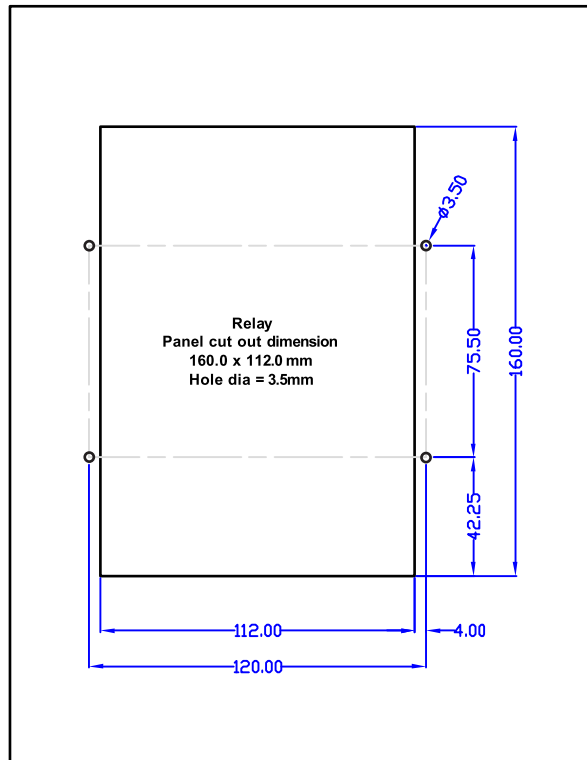

(Figure 14)

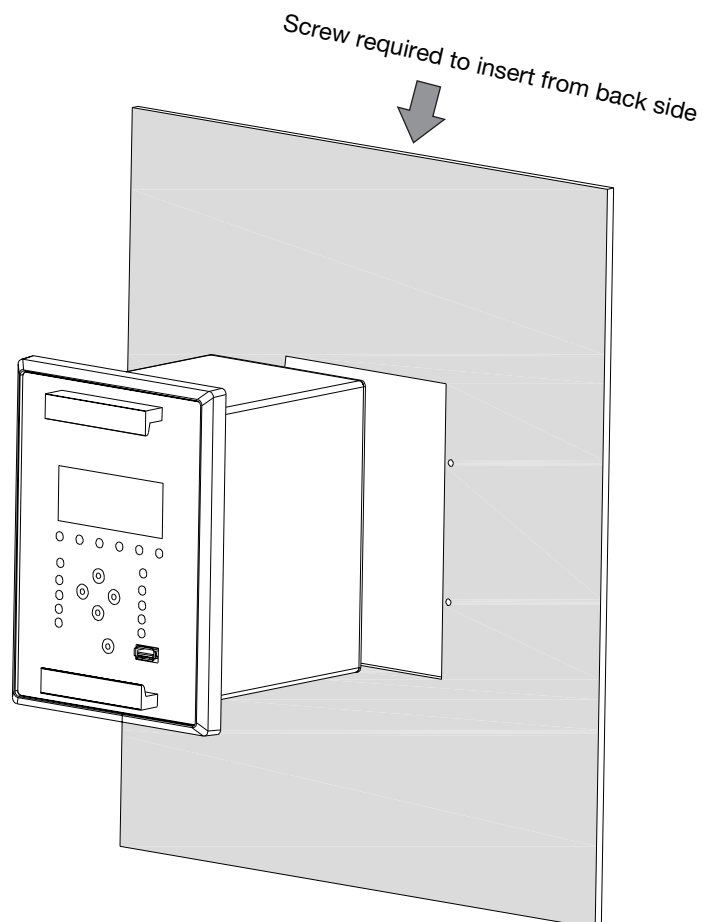

(Figure 15)

22) Ordering Information

CSENEX-I - 450 - D3 - X - M

AUXILIARY SUPPLY
H : 85 - 280V AC / 90V - 300V DC
W : 18 - 160V DC

Revision History

S.No.	Rev.No.	Details	Date
01	01	Inclusion of NPS Description (Pg.5) and its table (Pg.15) in the catalogue	07.07.16
02	01	Inclusion of Self supervision function line in page 3	07.07.16
03	02	Change in Front Sticker design, Inclusion of I>>> & t>>> parameter values in table	12.07.16
04	03	Inclusion of Lugs Photo on Page 26	07.11.16
05	05	Phase Over current Protection setting	16.12.16

**Technical Question or After-sales Service***Customer Center Quick Response
Service, Excellent Technical Support***1800 572 2012**

For further information, please contact:

**C&S Electric Ltd.
(Protection & Measurement Devices)**C-60, Wing-A, Phase-II, Noida-201 305, Dist: Gautam Budh Nagar (U.P) INDIA
Phone : +91-120-38748 00 / 01 Fax: +91-120-3874802 E-mail: cspc@cselectric.co.in**Branch office**

Branch	Phone	Fax	E-mail
Ahmedabad:	+91-79-615651 22/23/24	+91-79-61565130	ahmedabad@cselectric.co.in
Bangalore:	+91-80-305703 72/73, 30570347	+91 2558 4839	bangalore@cselectric.co.in
Bhubaneswar:	+91-674-2507265	+91 674 2507265	bhubaneswar@cselectric.co.in
Chennai:	+91-44-33534501,33534521-23	----	chennai@cselectric.co.in
Cochin:	+91-484-3071717	+91 0484 3071716	cochin@cselectric.co.in
Delhi:	+91-11-338490 00/10/11	+91 11 30838826	delhi@cselectric.co.in
Hyderabad:	+91-40-485340 80/82	----	hyderabad@cselectric.co.in
Kolkata:	+91-33-392121 19-21	----	----
Mumbai:	+91-22-241147 27/28	----	cspc.mumbai@cselectric.co.in
Pune:	+91-20-242505 18/19	+91 20 30283244	pune@cselectric.co.in

We touch your electricity everyday!